



100th
Anniversary
1911 Benelli 2011

Pure Passion since 1911

Café 1130Racer

MY 2011

ver. 01 Giugno 2011

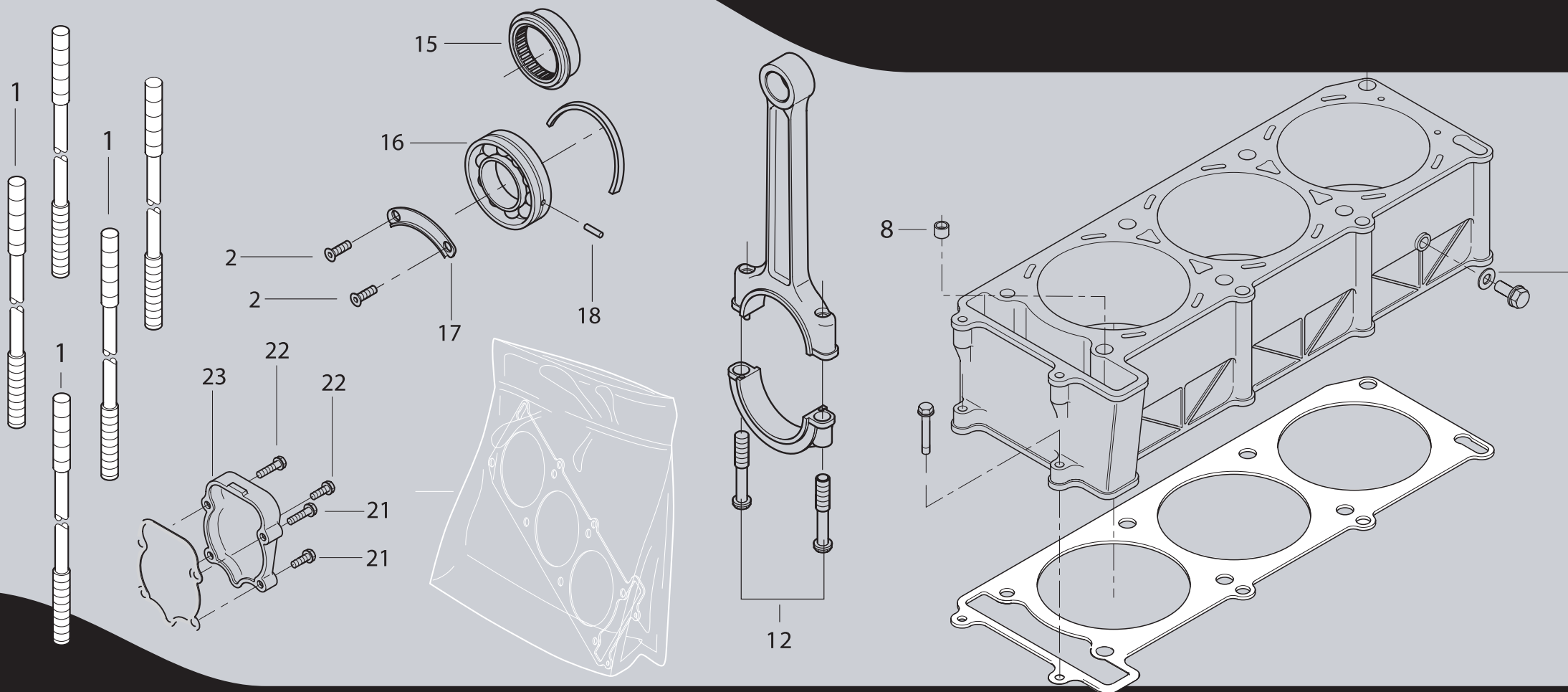

QUESTO CATALOGO SERVE PER RICHIEDERE CON ESATTEZZA LE PARTI DI RICAMBIO.

NELLE ORDINAZIONI INDICARE: IL NUMERO DEI CODICI DEI PARTICOLARI SEGUITO DALLA DESCRIZIONE E LA QUANTITÀ DESIDERATA.

LE INDICAZIONI CON LE FRECCIE SI RIFERISCONO AI LATI DEL VEICOLO RISPETTO AL SENSO DI MARCIA.

I DISEGNI DELLE PARTI DI RICAMBIO SONO SOLO INDICATIVI E NON RAPPRESENTANO IL PEZZO IN OGGETTO.

I DATI CONTENUTI IN QUESTO CATALOGO SONO INDICATIVI E POSSONO ESSERE SOGGETTI A MODIFICHE SENZA IMPEGNO DI PREAVVISO.

THE PRESENT SPARE PARTS ORDER EXACTLY THE RIGHT SPARE PARTS.

WHEN ORDERING SPECIFY: THE PART'S CODE NUMBER FOLLOWED BY ITS DESCRIPTION AND QUANTITY NEEDED.

REFERENCE WITH ARROWS APPLY TO THE VEHICLE IN TERMS OF ITS DIRECTION OF MOVEMENT.

SPARE PARTS DRAWINGS ARE GENERAL AND DO NOT REPRESENT THE PART.

THE CONTENTS OF THIS CATALOGUE ARE GENERAL AND CAN UNDERGO CHANGES WITHOUT PRIOR NOTICE.

CE CATALOGUE PERMET DE COMMANDER CORRECTEMENT LES PIÈCES DÉTACHÉES.

LES COMMANDES DOIVENT ÊTRE PASSÉES EN INDIQUANT: LE NUMERO DE CODE DES PIÈCES DÉTACHÉES SUIVI DE LEUR DESCRIPTION ET QUANTITÉ DÉSIRÉE.

RÉFÉRENCE AVEC DES FLÈCHES SONT LES CÔTÉS DU VÉHICULE PAR RAPPORT AU SENS DE LA MARCHÉ.

LES PLANS DES PIÈCES DÉTACHÉES SONT FOURNIS SEULEMENT À TITRE INDICATIF ET NE REPRÉSENTENT PAS LA PIÈCE CONCERNÉE.

LES DONNÉES DE CE CATALOGUE SONT CITÉES SEULEMENT À TITRE INDICATIF ET PEUVENT ÊTRE L'OBJET DE MODIFICATIONS SANS AVIS PRÉALABLE.

DIESER ERSATZTEILKATALOG DIEN ZUR GENAUEN ANGABE DER TEILE BEI ERSATZTEILBESTELLUNGEN.

BEIERSATZBESTELLUNG IST FOLGENDES ANZUGEBEN: DIE BESTELLNUMMER DER ERSATZTEILE MIT DER ENTSPRECHENDEN BESCHREIBUNG UND GENAUEN MENGE.

DIE ANGABEN MIT PFEILE BEZIEHEN SICH AUF DAS FAHRZEUG IN FAHRRICHTUNG.

DIE ZEICHNUNGEN DER ERSATZTEILE SIND NUR ALS HINWEISE GEDACHT UND STELLEN NICHT DAS BETROFFENE TEIL DAR.

BEI DEN IM KATALOG ANGEFÜHRTEN DATEN HANDELT ES SICH UM ANHALTSDATEN, DIE JEDERZEIT, OHNE VORANKÜNDIGUNG, GEÄNDERT WERDEN KÖNNEN.

EL PRESENTE CATÁLOGO SIRVE PARA PEDIR CON EXACTITUD LAS PARTES DE REPUESTO.

EN LOS PEDIDOS SE DEBE INDICAR: EL NÚMERO DE CÓDIGO DE LA PARTE Y A CONTINUACIÓN LA DESCRIPCIÓN Y CANTIDAD DESEADA.

LAS INDICACIONES CON LAS FLECHAS SE REFIEREN A LOS LADOS DEL VEHÍCULO RESPECTO DEL SENTIDO DE MARCHA.

LOS DISEÑOS DE LAS PARTES DE RECAMBIO SON SOLO INDICATIVOS Y NO REPRESENTAN LA PIEZA EN CUESTIÓN.

LOS DATOS CONTENIDOS EN EL PRESENTE CATÁLOGO SON INDICATIVOS Y PUEDEN MODIFICARSE SIN AVISO PREVIO.

1911

Benelli

2011



00A	ATTREZZI SPECIALI	SPECIAL TOOLS	OUTILS SPECIAUX	SONDERWERKZEUGE	HERRAMENTAL ESPECIALES
001	DISTRIBUZIONE	TIMING	DISTRIBUTION	VENTILSTEUERUNG	DISTRIBUCIÓN
002	GRUPPO TESTA	CYLINDER HEAD	GROUPE CULASSE	ZYLINDERKOPFGRUPPE	GRUPO CULATA
003	CILINDRO PISTONI	CYLINDER PISTONS	CYLLINDRE PISTONS	ZYLINDER KOLBEN	CILINDRO PISTONES
004	ASSIEME MANOVELLISMO	CRANK GEAR ASSEMBLY	ENSEMBLE BIELLISME	KURBELGETRIEBE KOMPLETT	JUNTO CINEMATISMO
005	COPPIA SEMICARTER	HALF CRANKCASES	DEMI-CARTERS	GEHÄUSEHÄLFTE	PAREJA SEMI-CARTER
006	ASSIEME CARTER	GUARD ASSEMBLY	ESEMBLE CARTERS	GEHÄUSE KOMPLETT	GRUPO CARTER
007	COPERCHI MOTORE	ENGINE COVERS	COUVERCLES MOTEUR	MOTOR DECKEL	TAPAS MOTOR
008	LUBRIFICAZIONE	LUBRIFICATION	LUBRIFICATION	SCHMERUNG	LUBRICACIÓN
009	POMPA ACQUA	WATER PUMP	POMPE EAU	WASSERPUMPE	BOMBA AGUA
010	FRIZIONE	CLUTCH	EMBRAYAGE	KUPPLUNG	EMBRAGUE
011	COMANDO CAMBIO	GEARCHANGE	COMMANDE BOÎTE A VITESSES	GANGSCHALTUNG	MANDO CAMBIO
012	CAMBIO	GEAR-BOX	BOÎTE A VITESSES	SCHALTUNG	CAMBIO
013	RADIATORE ACQUA	WATER RADIATOR	RADIATEUR D'EAU	WASSERKUEHLER	RADIATOR AGUA
014	CIRCUITO DI RAFFREDDAMENTO	COOLING CIRCUIT	CIRCUIT DE REFRROIDISSEMENT	KÜHLREISLAUF	CIRCUITO DE REFRIGERADOR
015	ALIMENTAZIONE	FEEDING	ALIMENTACION	VERSORGUNG	ALIMENTACIÓN
016	ASPIRAZIONE	INTAKE	ASPIRATION	LUFTEINZUG	ASPIRACIÓN
017	GRUPPO SCARICO	EXHAUST SYSTEM	ECHAPPEMENT	AUSPUFFANLAGE	GRUPO ESCAPE
018	IMPIANTO ELETTRICO	ELECTRIC SYSTEM	INSTALLATION ELECTRIQUE	ELEKTRISCHE ANLAGE	SISTEMA ELECTRICO
019	AVVIAMENTO ELETTRICO	ELECTRIC STARTER	DEMARRAGE ELECTRONIQUE	ELEKTROSTARTER ANLASSER	PUESTA EN MARCHA ELECTRICA
020	STRUMENTAZIONE	INSTRUMENTATION	INSTRUMENTATION	INSTRUMENTEN-AUSRÜSTUNG	INSTRUMENTACIÓN
021	SENSORI	SENSORS	CAPTEURS	SENSOR	SENSORS
022	FANALI	HEAD-LIGHTS	PHARES	SCHEINWERFERS	FAROS
023	TELAIO	FRAME	CADRE	RAHMEN	CHASIS
024	CAVALLETTO	STAND	BEQUILLE	BOCK	CABALLETTE
025	FORCELLONE	SWINGARM	FOURCHE	SCHWINGE	BASCULANTE
026	ASSIEME FORCELLONE	SWING ARM ASSEMBLY	ENSEMBLE FOURCHE	GABEL KOMPLETT	GRUPO BASCULANTE
027	SOSPENSIONE POSTERIORE	REAR SUSPENSION	SUSPENSION ARRIÈRE	HINTERRADFEDERUNG	SUSPENSION TRASERA
028	CODONE	TAIL GUARD	CORPS DE SELLE	HECK	CUERPO ASIENRO
029	SCATOLA BATTERIA	BATTERY BOX	BOÎTE BATTERIE	BATTERIEGEHÄUSE	CAJA BATERÍA
030	PORTATARGA	NUMBER PLATE HOLDER	PORTE-PLAQUE	NUMMERSCHILDTAFEL	PORTA-MATRÍCULA
031	PEDANE ANTERIORI	FRONT FOOD PEG	REPOSE PIEDS AVANT	VORDERE FUSSRASTE	ESTRIBERAS DELANTERA
032	PEDANE POSTERIORI	REAR FOOT PEG	REPOSE PIEDS ARRIÈRE	HINTERE FUSSRASTE	ESTRIBERAS TRASERA
033	PARAFANGO ANTERIORE	FRONT MUDGUARD	GARDE-BOUE AVANT	VORDERES SCHUTZBLECH	GUARDABARROS DELANTERO
034	PARAFANGO POSTERIORE	REAR MUDGUARD	GARDE-BOUE ARRIÈRE	HINTERE SCHUTZBLECH	GUARDABARROS TRASERO
035	FORCELLA ANTERIORE	FRONT FORK	FOURCHE AVANT	TELEGABEL	HORQUILLA DELANTERA
036	MANUBRIO E COMANDI	HANDLEBAR AND CONTROLS	GUIDON ET COMANDES	LENKER UND STEUERORGANE	MANILLAR Y MANDOS
037	FRENO ANTERIORE	FRONT BRAKE	FREIN AVANT	VORD BREMSE	FRENO DELANTERO
038	FRENO POSTERIORE	REAR BRAKE	FREIN ARRIÈRE	HINTERBREMSE	FRENO TRASERO
039	RUOTA ANTERIORE	FRONT WHEEL	ROUE AVANT	VORDERRAD	RUEDA DELANTERA
040	RUOTA POSTERIORE	REAR WHEEL	ROUE ARRIÈRE	HINTERRAD	RUEDA TRASERA
041	CUPOLINO	HEADLIGHT FAIRING	CARÉNAGE	FAHRTWINDSCHUTZ	CÚPULA
042	CARENATURE	FAIRING	CARÉNAGE	SCHALE	BASTIDOR
043	SERBATOIO	FUEL TANK	RÉSERVOIR CARBURANT	KRAFTSTOFFTANK	DEPÓSITO GASOLINA
044	SERRATURE	LOCKS	SERRURE	SCHLOß	CERRADURES
045	PROTEZIONE MOTORE	ENGINE PROTECTION	PROTECTION MOTEUR	SCHUTZ MOTOR	PROTECCIÓN MOTOR
046	COPERCHIO SELLA	COVER SEAT	COUVERCLE SELLE	BEIFAHRSITZABDECKUNG	TAPA SILLÓN

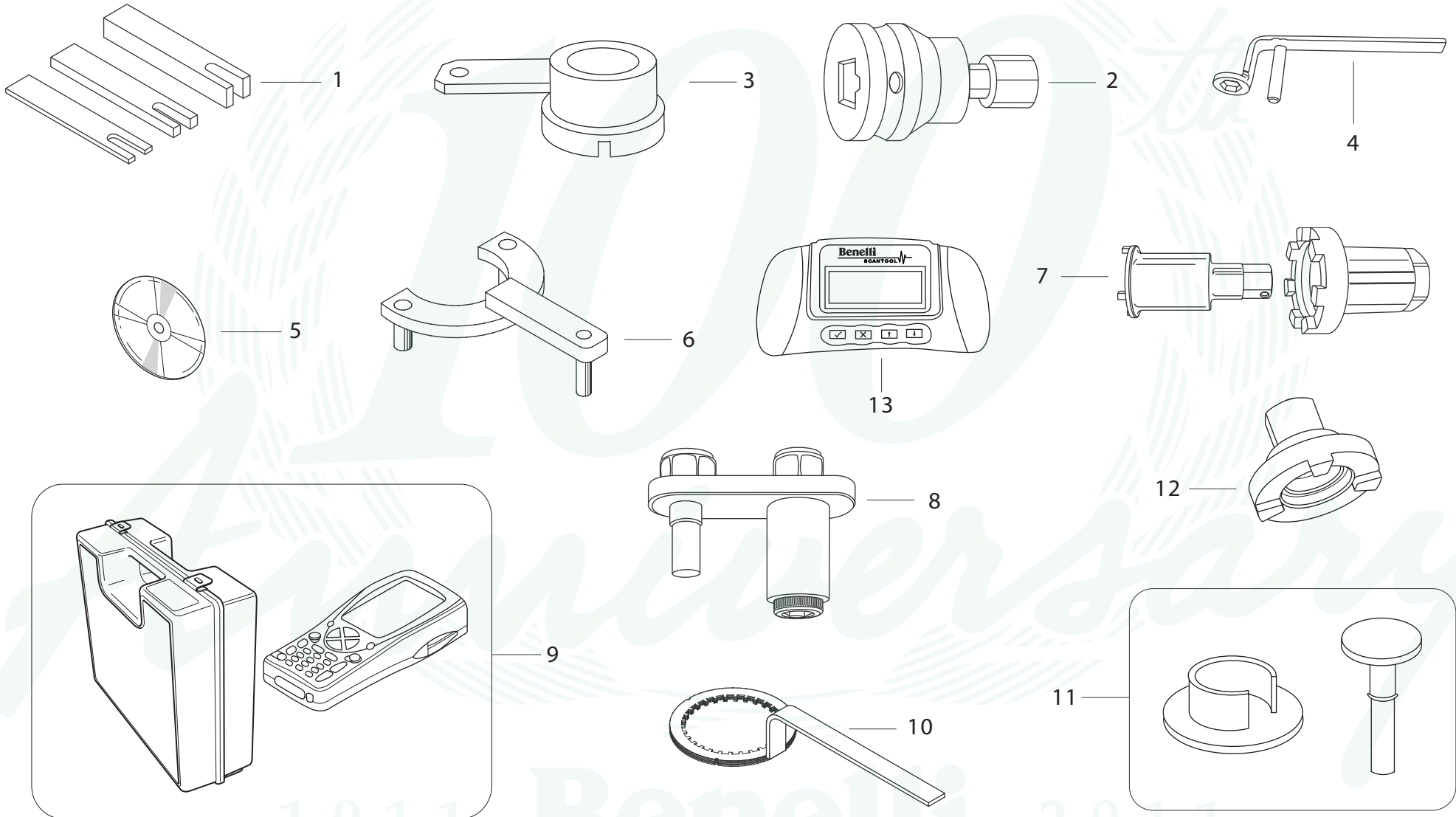

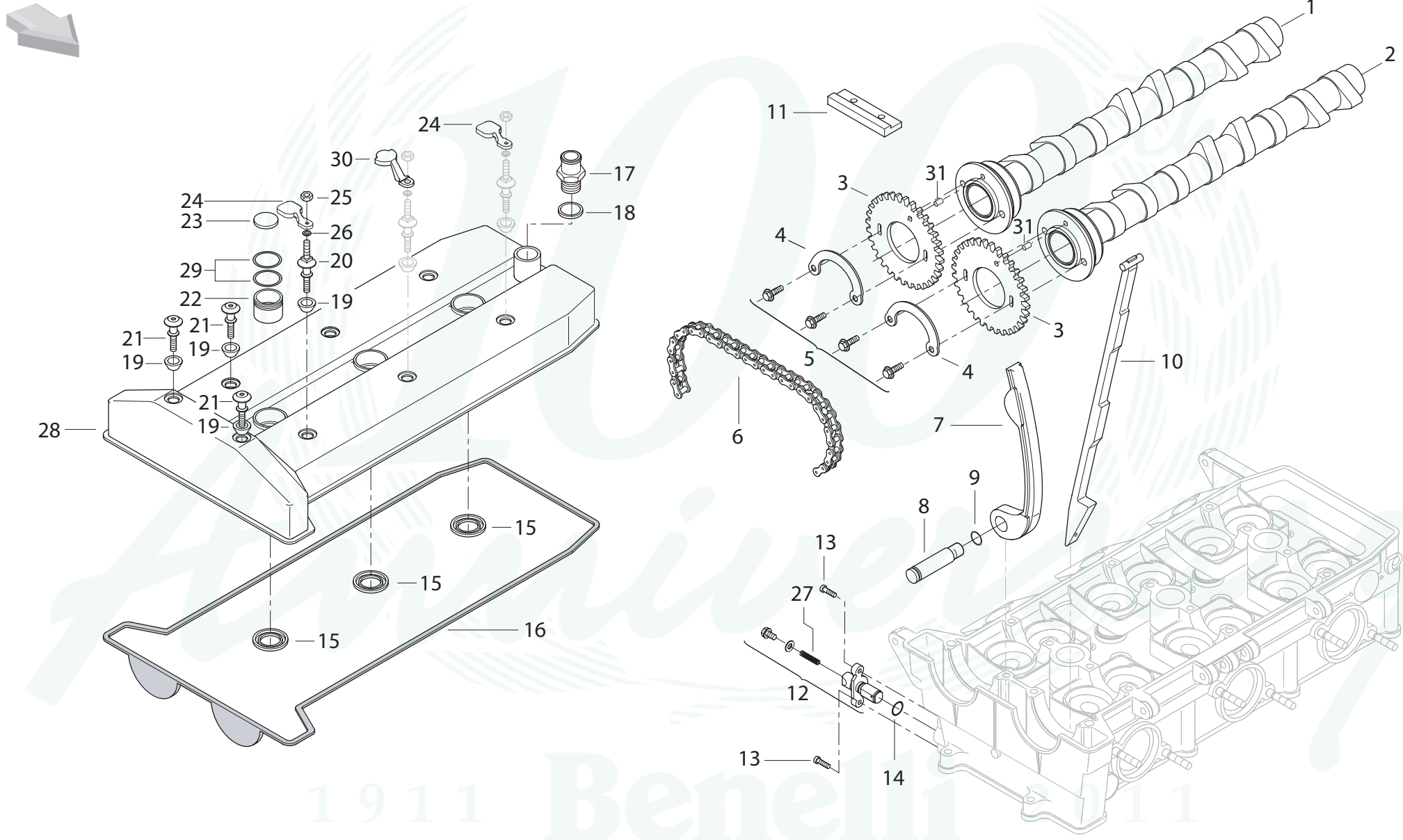

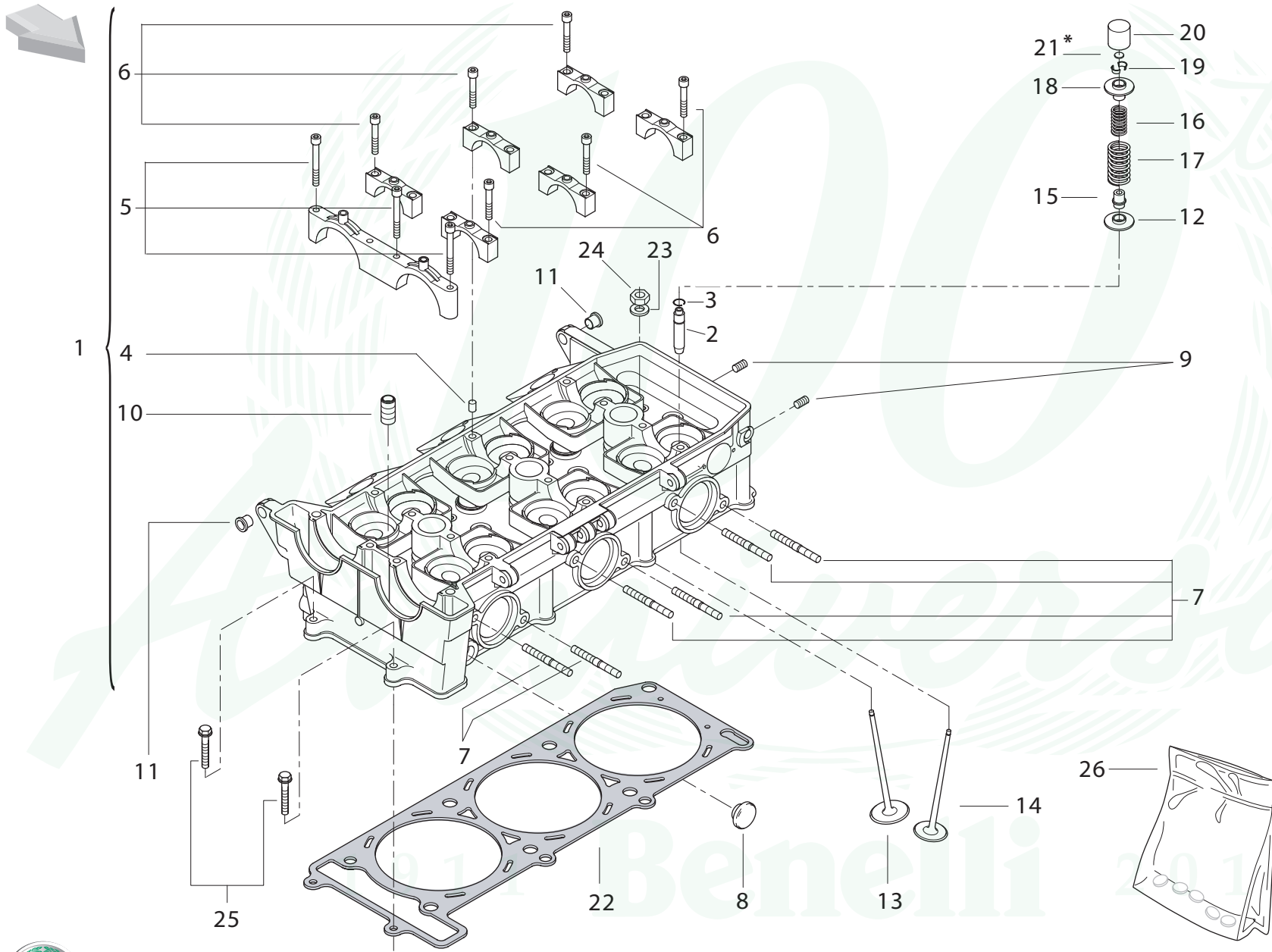

MISURA PASTIGLIA VALVOLE VALVES PAD MEASURE MESURE PASTILLE MASS PASTILLE VENTIL MEDIDA PASTILLA VÁLVULAS	
Codice Code Code Code Codice	
R14214641A	2,8 mm
R14214631A	2,775 mm
R14214621A	2,75 mm
R14214611A	2,725 mm
R14214601A	2,7 mm
R14214591A	2,675 mm
R14214581A	2,65 mm
R14214571A	2,625 mm
R14214561A	2,6 mm
R14214551A	2,575 mm
R14214541A	2,55 mm
R14214531A	2,525 mm
R14214521A	2,5 mm
R14214511A	2,475 mm
R14214501A	2,45 mm
R14214491A	2,425 mm
R14214481A	2,4 mm
R14214471A	2,375 mm
R14214461A	2,35 mm
R14214451A	2,325 mm
R14214441A	2,3 mm
R14214431A	2,275 mm
R14214421A	2,25 mm
R14214411A	2,225 mm
R14214401A	2,2 mm
R14214391A	2,175 mm
R14214381A	2,15 mm
R14214371A	2,275 mm
R14214361A	2,25 mm
R14214351A	2,225 mm
R14214341A	2,200 mm
R14214331A	2,025 mm
R14214321A	2,050 mm
R14214311A	2,075 mm
R14214301A	1,950 mm
R14214311A	1,975 mm



CILINDRO PISTONI

🇮🇹 CILINDRO PISTONI

🇬🇧 CYLINDER PISTONS

🇫🇷 CYLINDRE PISTONS

🇩🇪 ZYLINDER KOLBEN

🇪🇸 CILINDRO PISTONES

TAVOLA
DRAWING
TABLE
BILD
TABLA

003

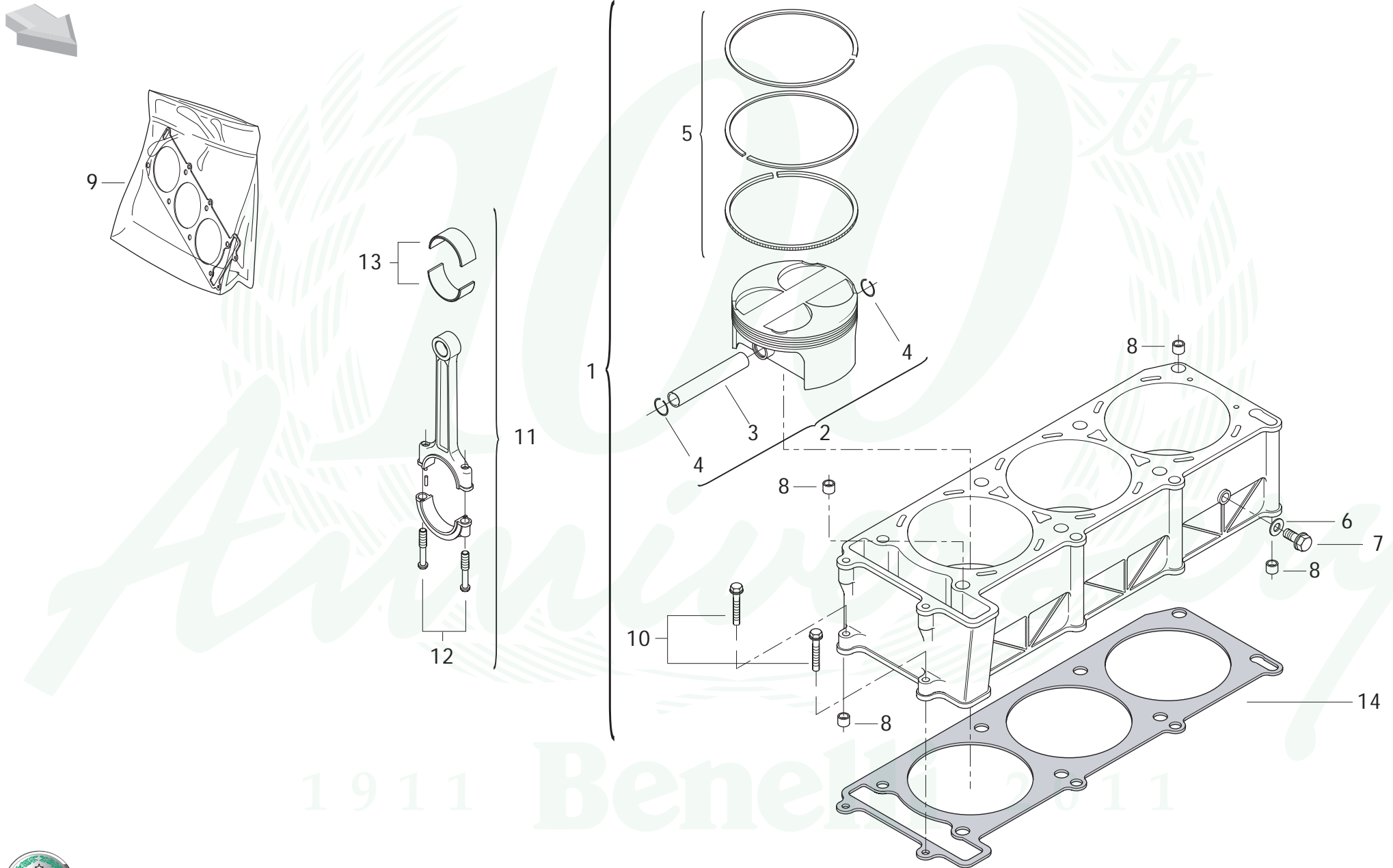

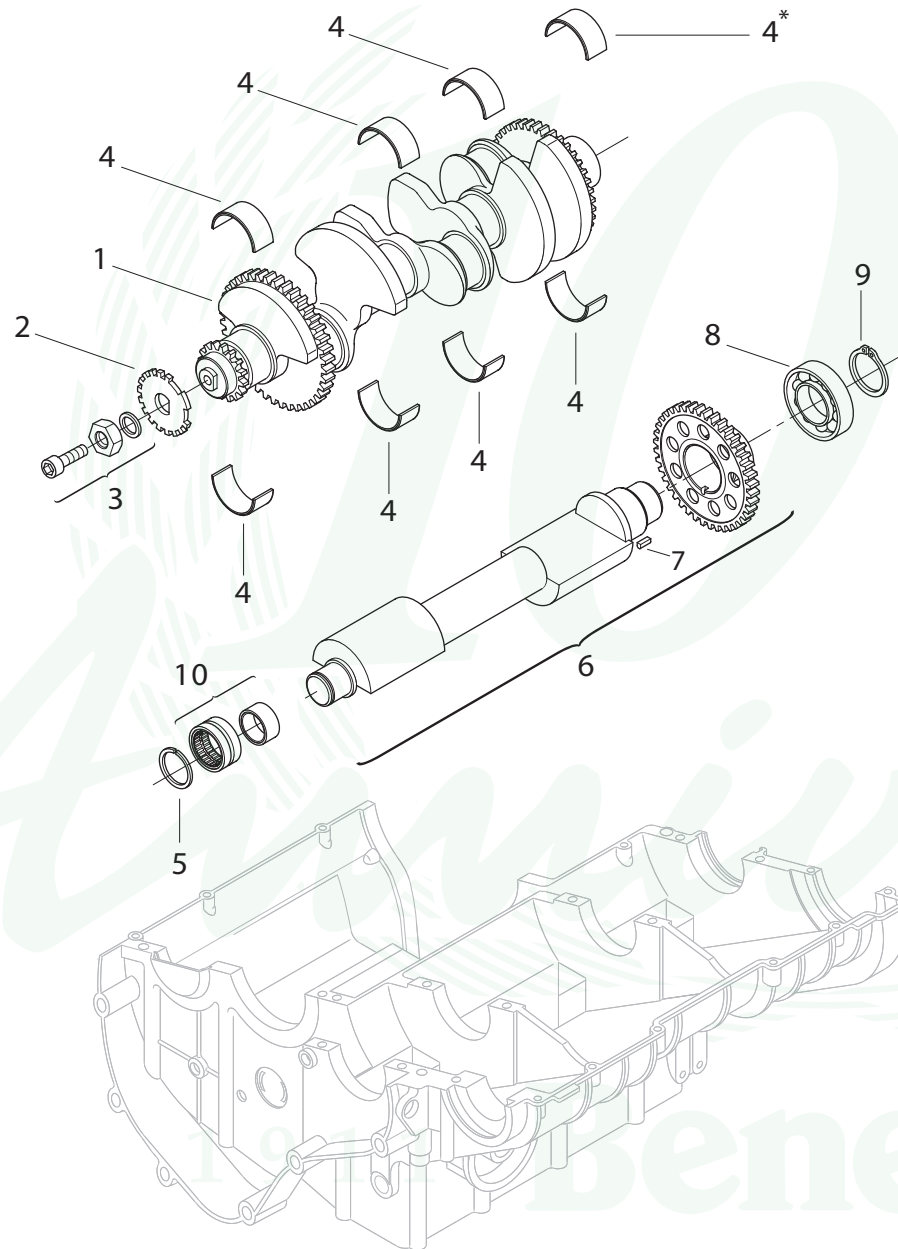

4*

SEMICUSCINETTO DI BANCO		
STD	COLORE COLOUR COULEUR FARBE COLOR	SELEZIONE SELECTION SELECTION AUSWAHL SELECCIÓN
A	Rosso Red Rouge Rot Rojo	1.918 - 1.922
B	Blu Blue Bleu Blau Azul	1.922 - 1.926
C	Giallo Yellow Jaune Gelb Amarillo	1.926 - 1.930
Ø sede std A rosso Ø seat std A red Ø siège std A rouge Ø sitz std A rot Ø sede std A rojo		41.830 - 41.836
Ø sede std A blu Ø seat std A blue Ø siège std A bleu Ø sitz std A blau Ø sede std A azul		41.837 - 41.843
Ø sede std A giallo Ø seat std A yellow Ø siège std A jaune Ø sitz std A gelb Ø sede std A amarillo		41.843 - 41.850
Ø albero std unico Ø single std shaft Ø arbre std unique Ø welle std einheitl Ø arbol std único		37.960 - 37.970

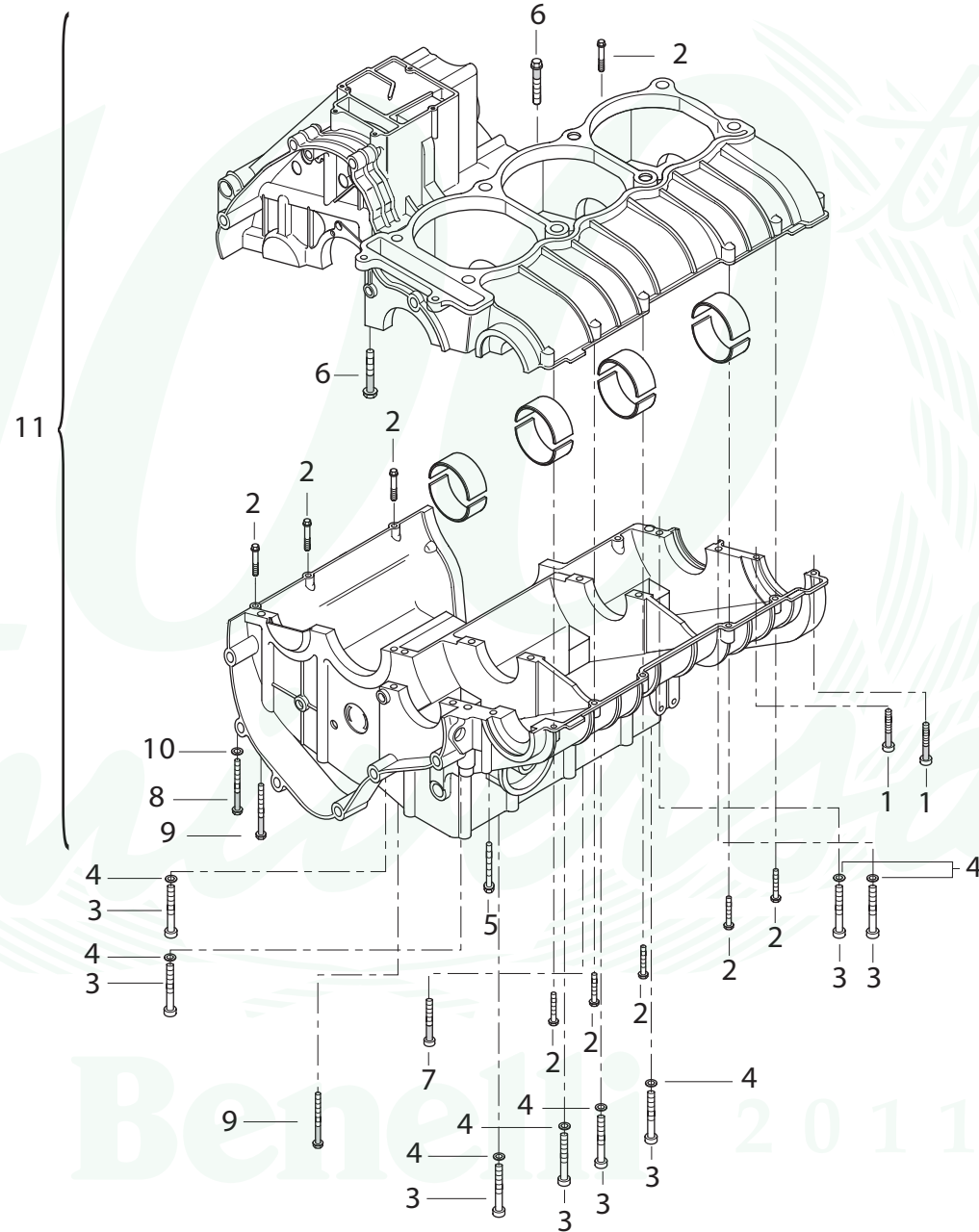

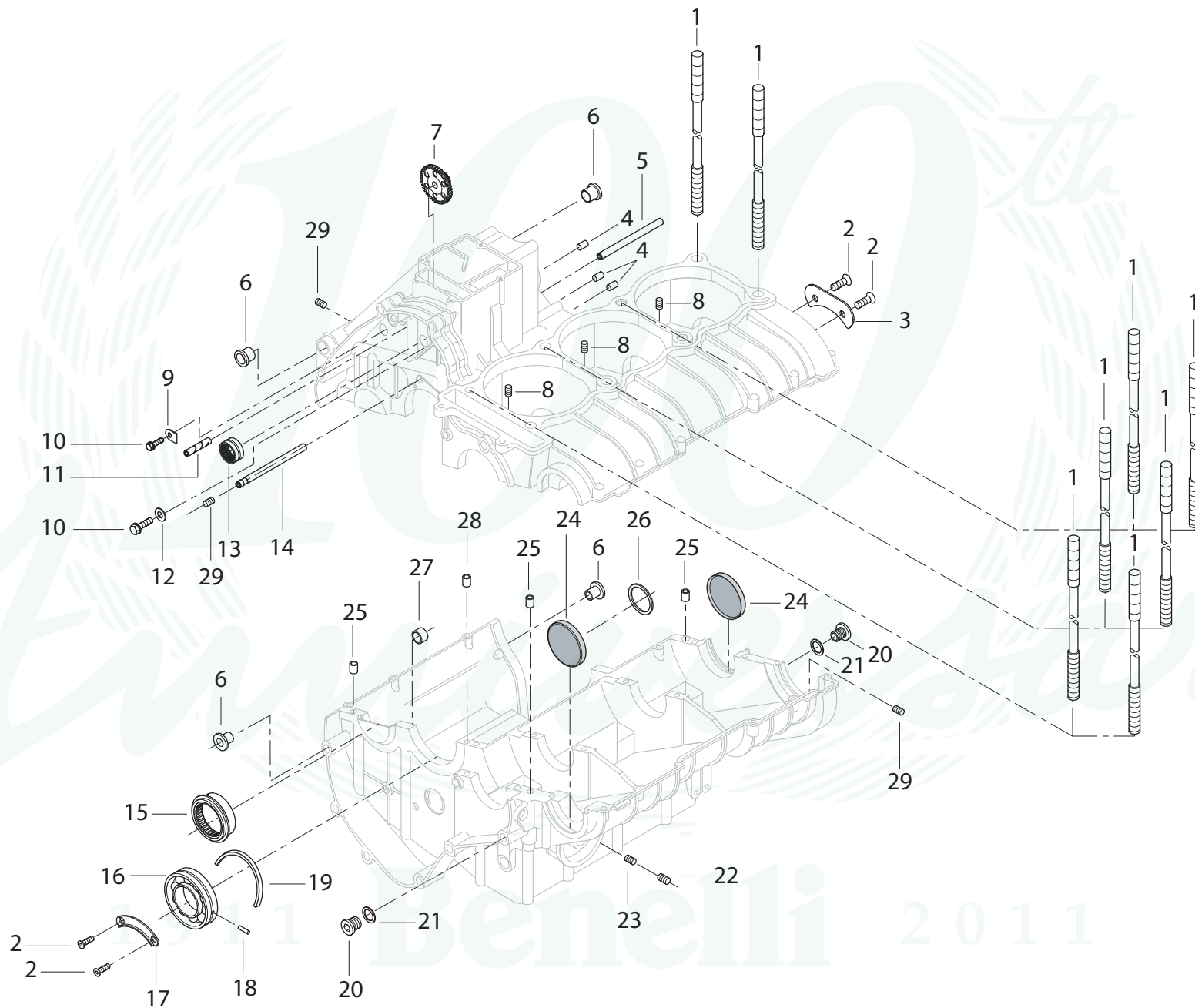

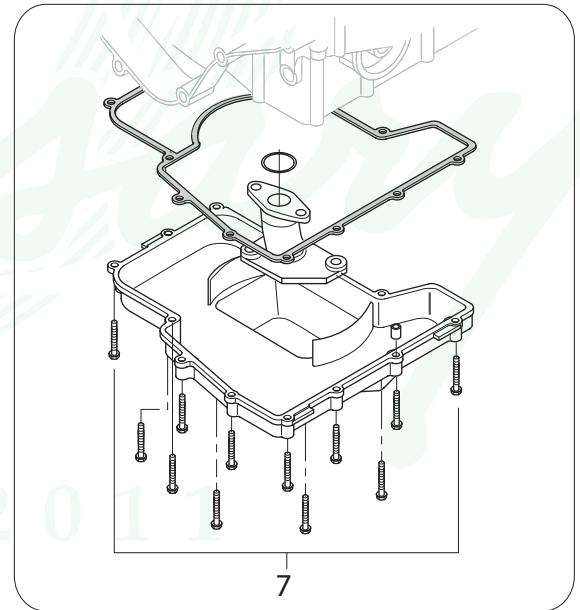
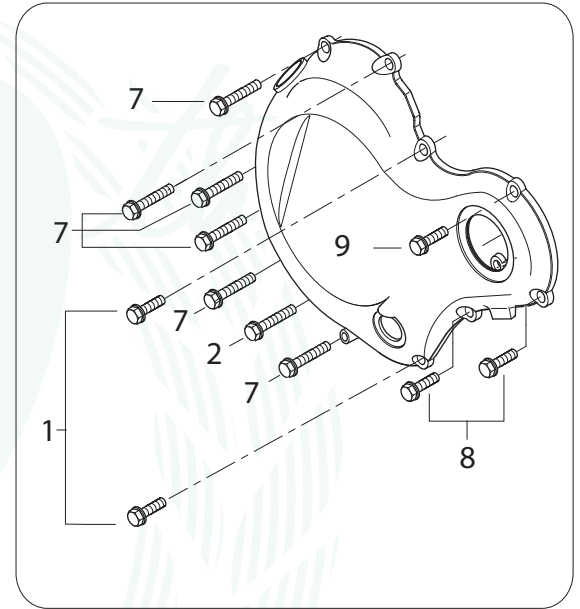
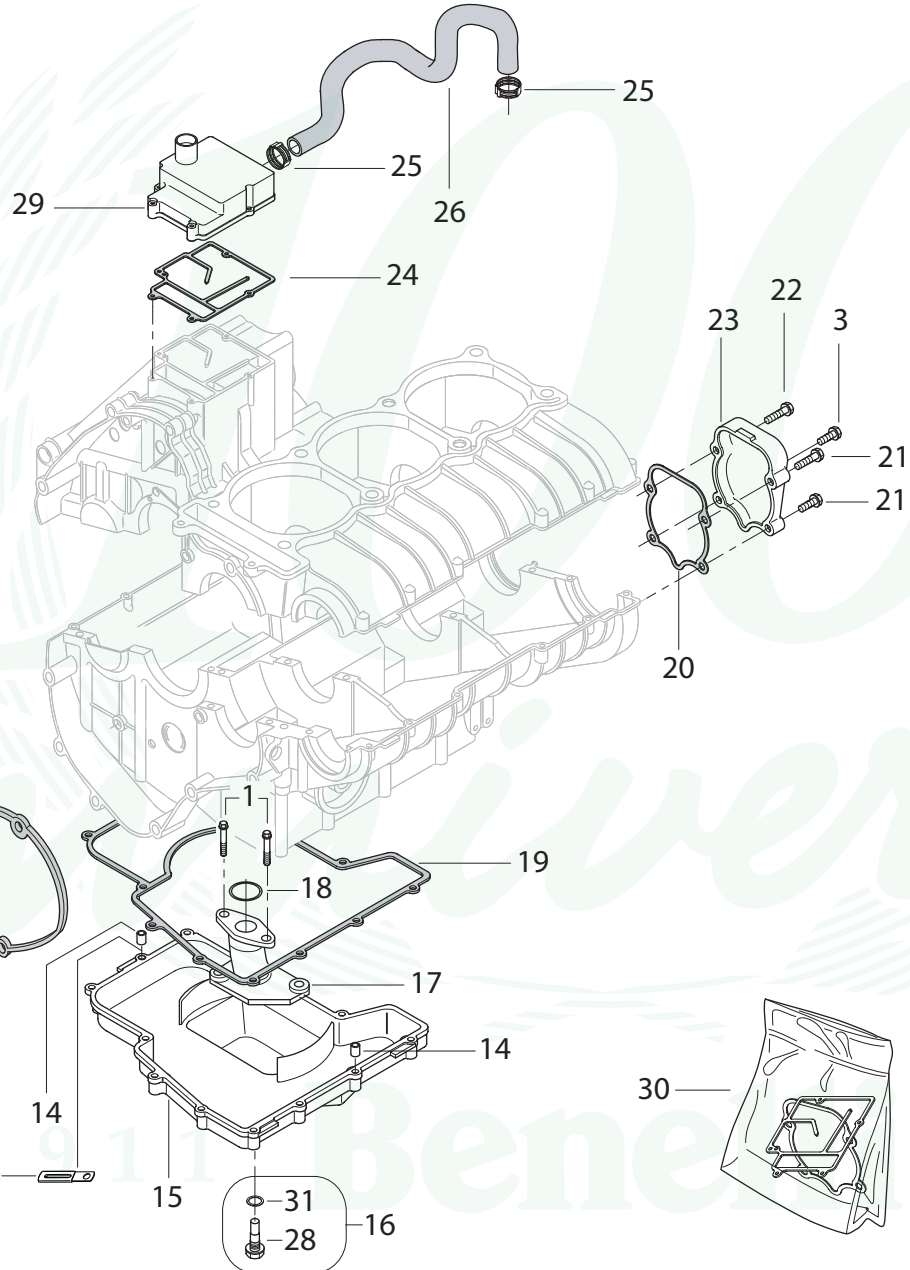
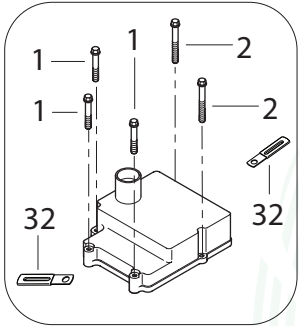

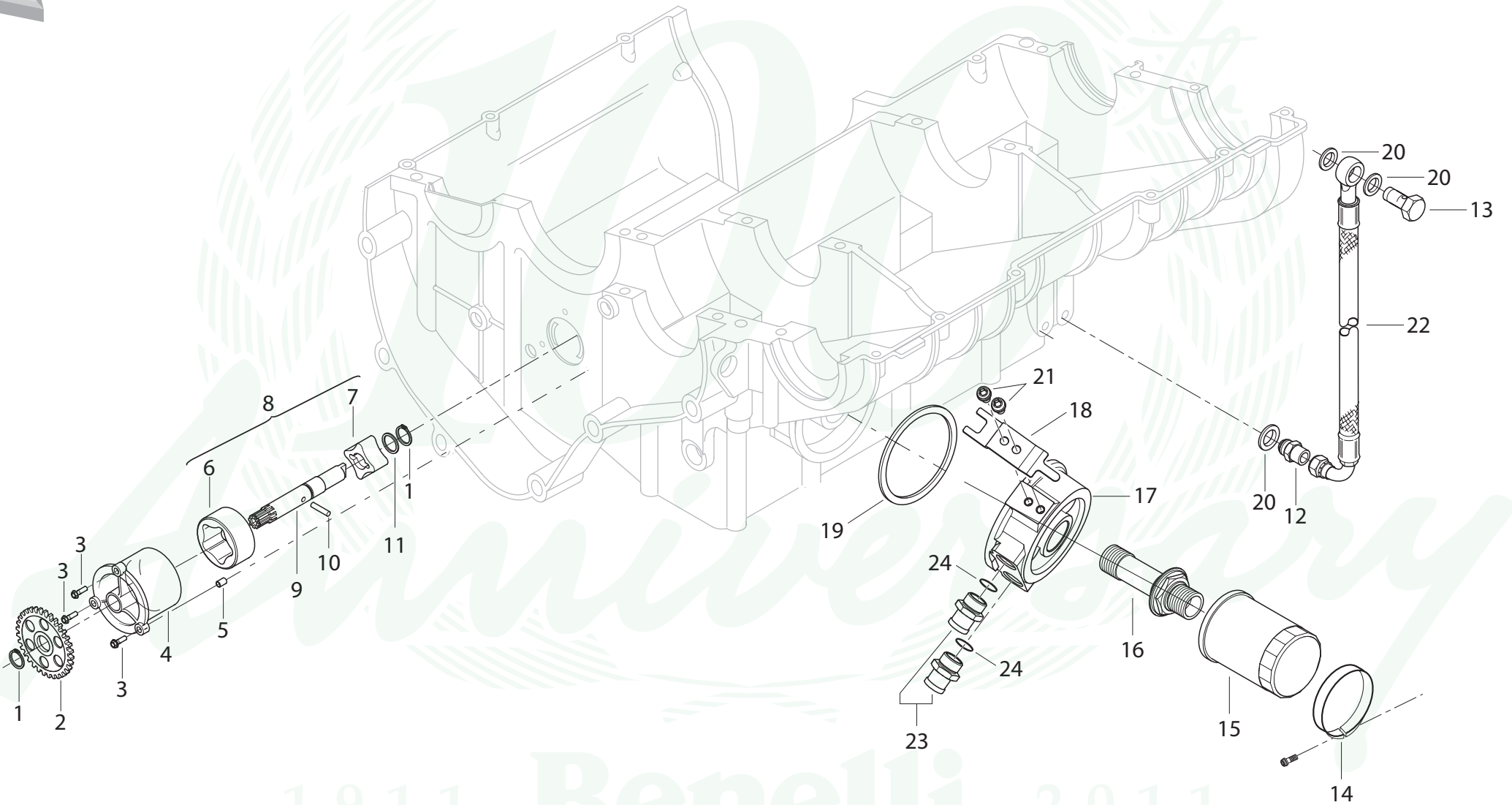

1911

Benelli

2011



POMPA ACQUA

 POMPA ACQUA

 WATER PUMP

 POMPE EAU

 WASSERPUMPE

 BOMBA AGUA

TAVOLA
DRAWING
TABLE
BILD
TABLA

009

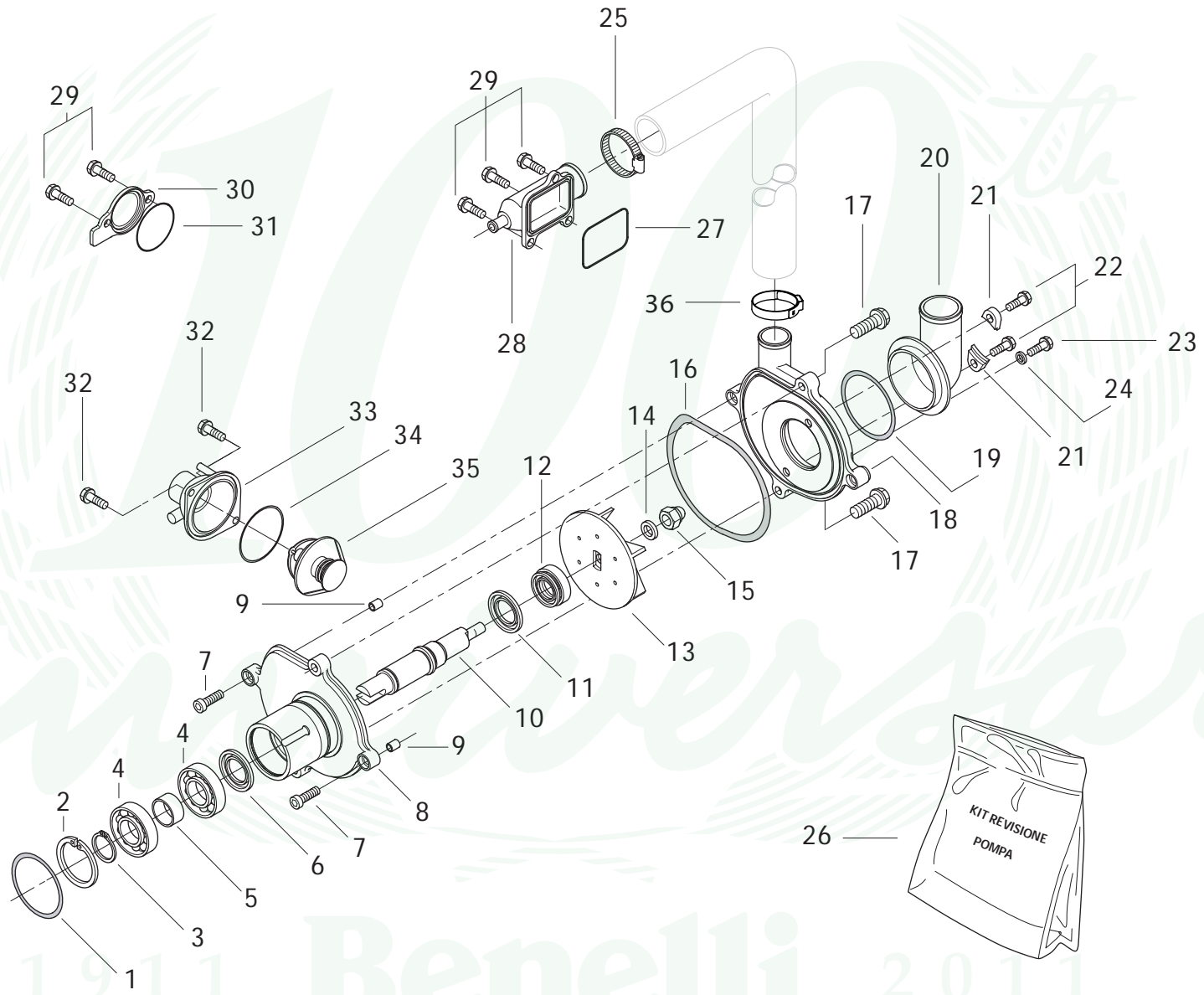

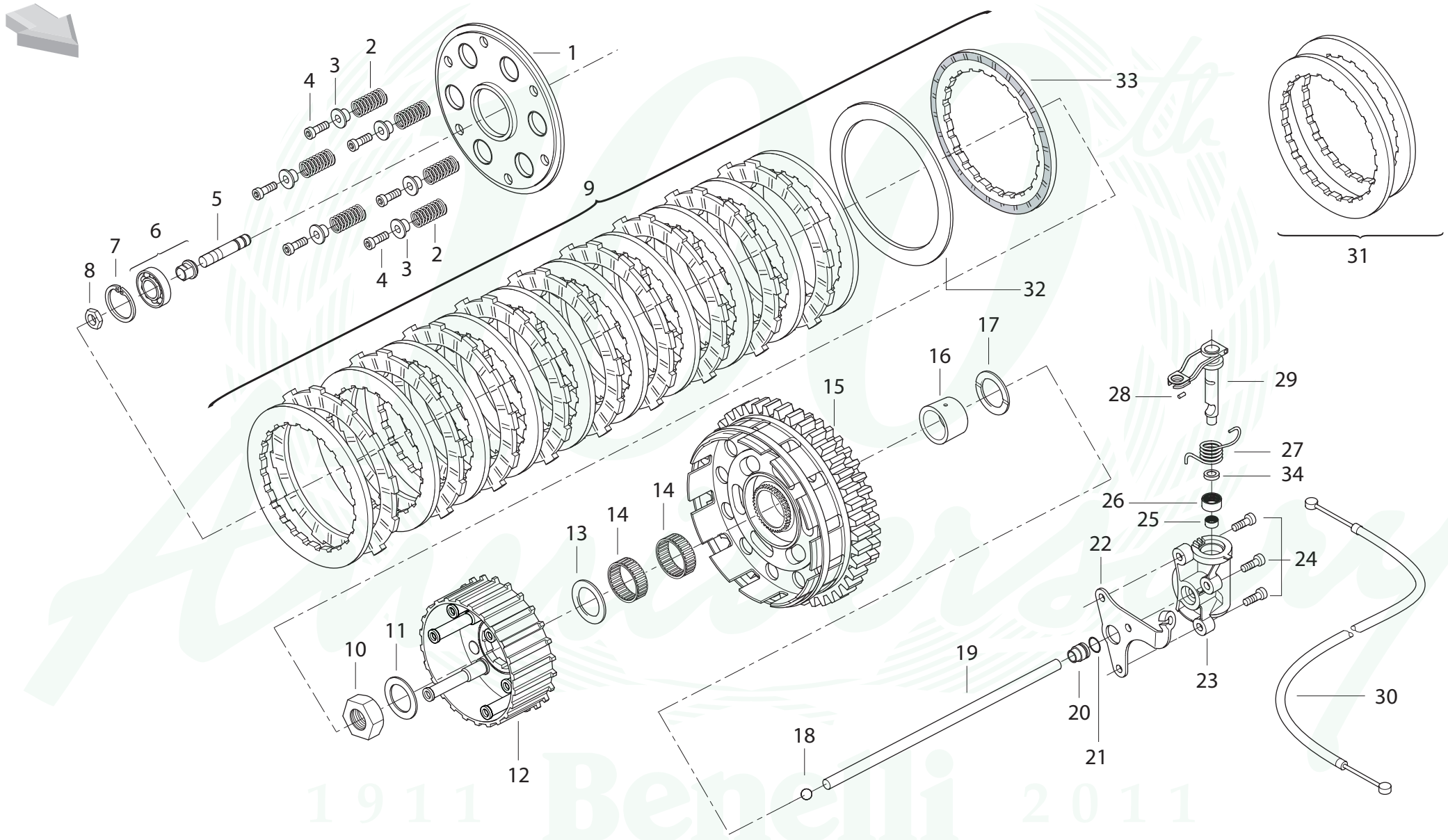

COMANDO CAMBIO

 COMANDO CAMBIO

 GEARCHANGE

 COMMANDE
BOITE A VITESSES

 GANGSCHALTUNG

 MANDO CAMBIO

TAVOLA
DRAWING
TABLE
BILD
TABLA

011

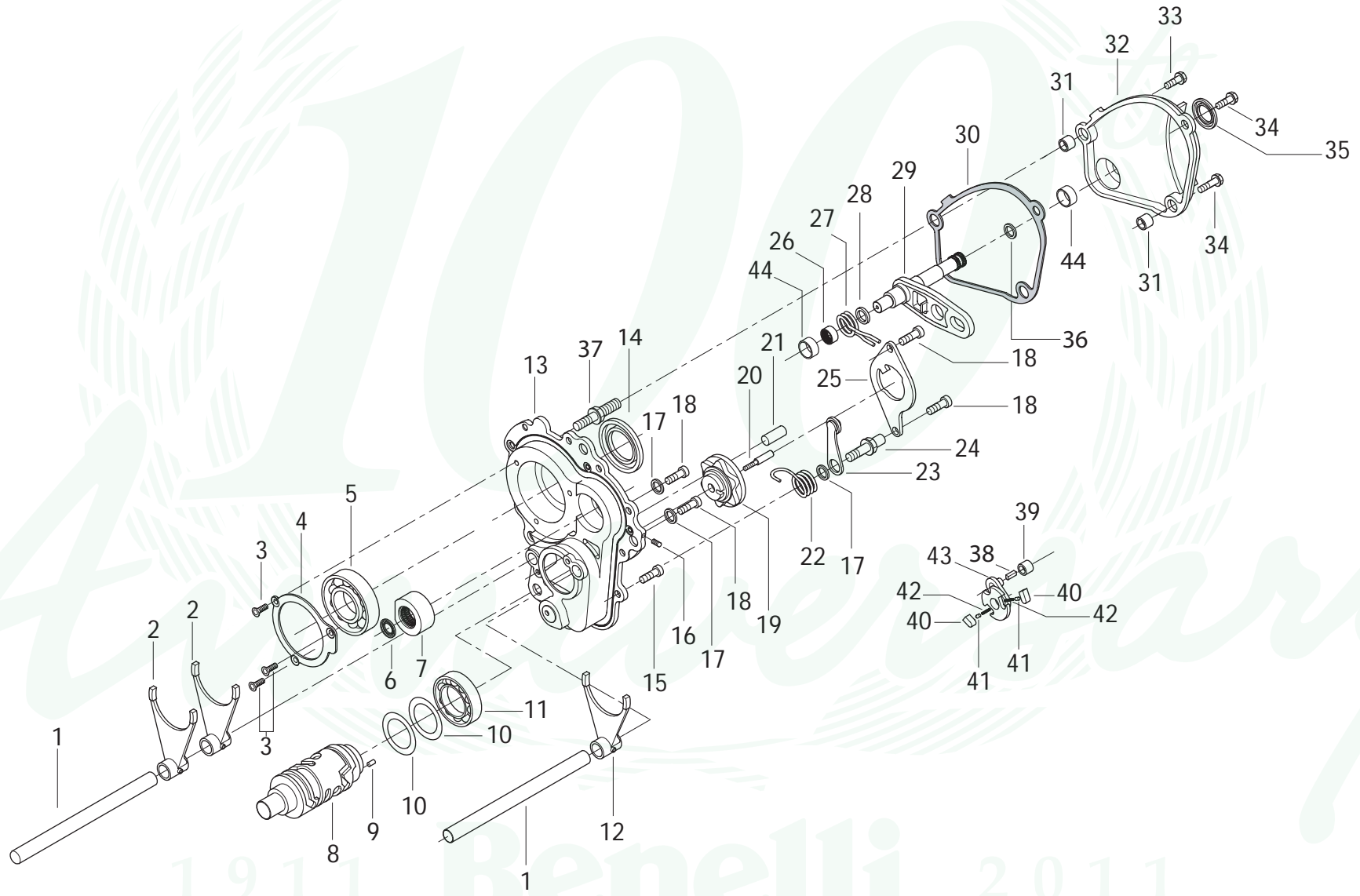

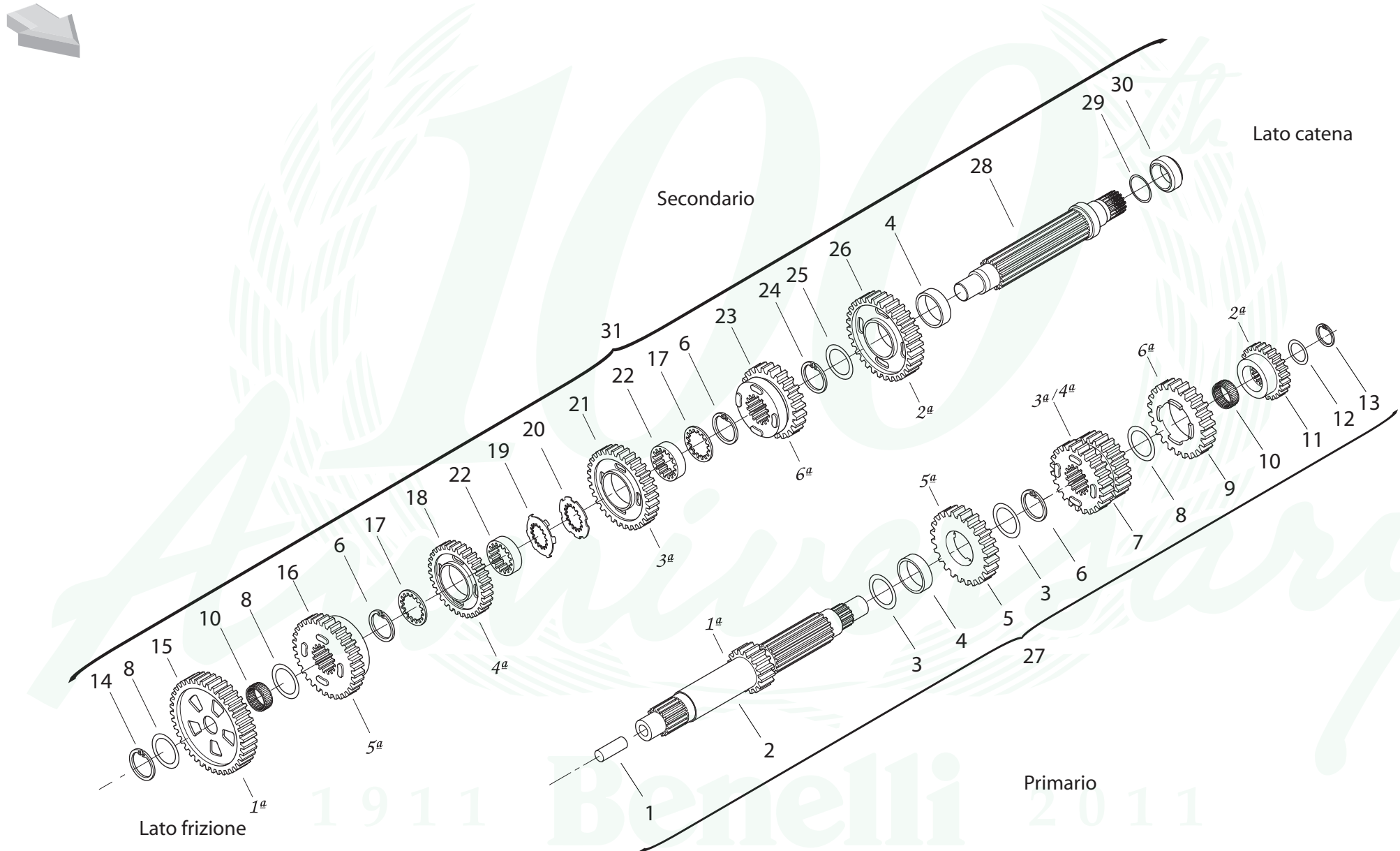

RADIATORE ACQUA

 RADIATORE ACQUA

 WATER RADIATOR

 RADIATEUR D'EAU

 WASSERKUEHLER

 RADIATOR AGUA

TAVOLA
DRAWING
TABLE
BILD
TABLA

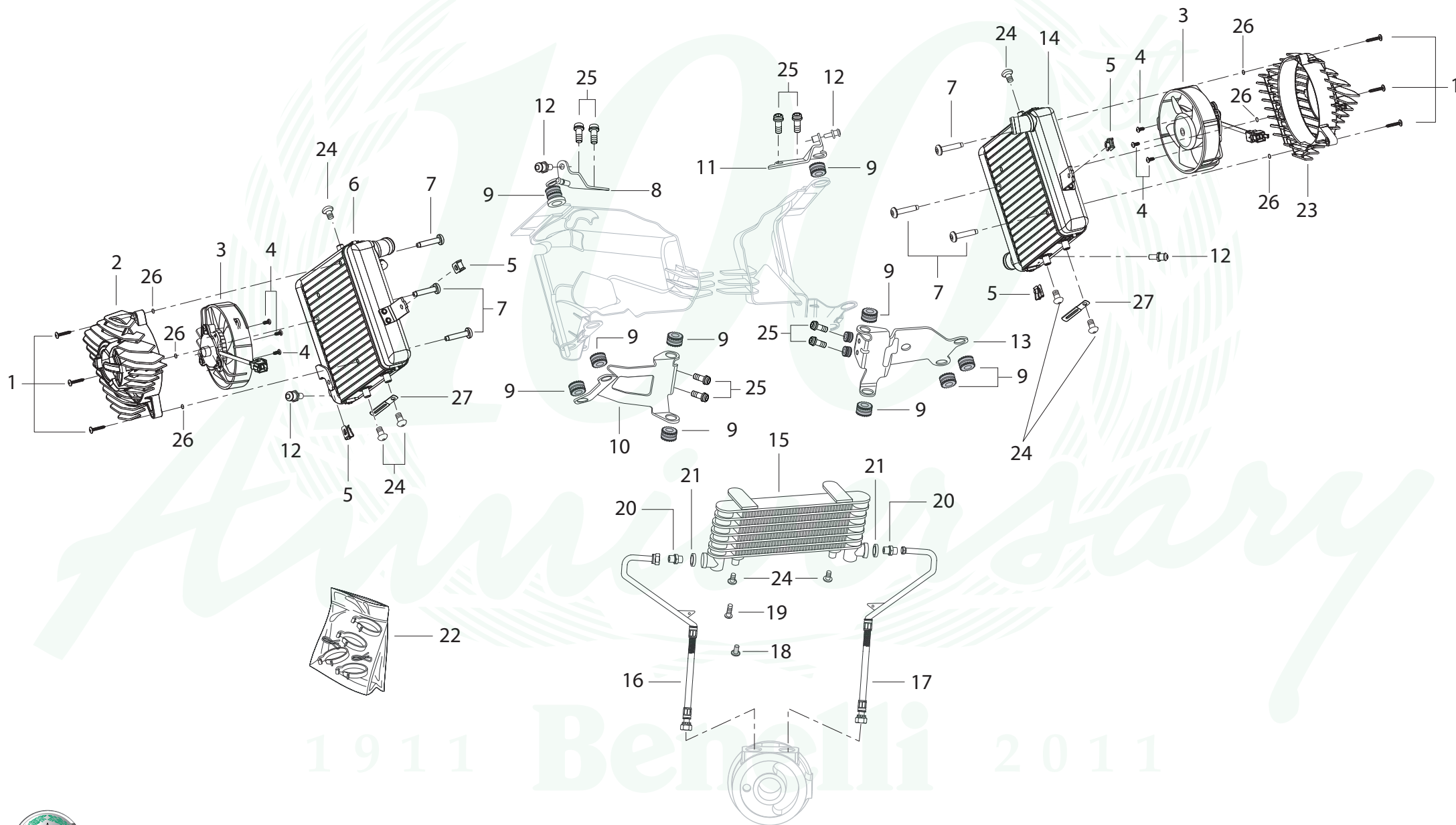

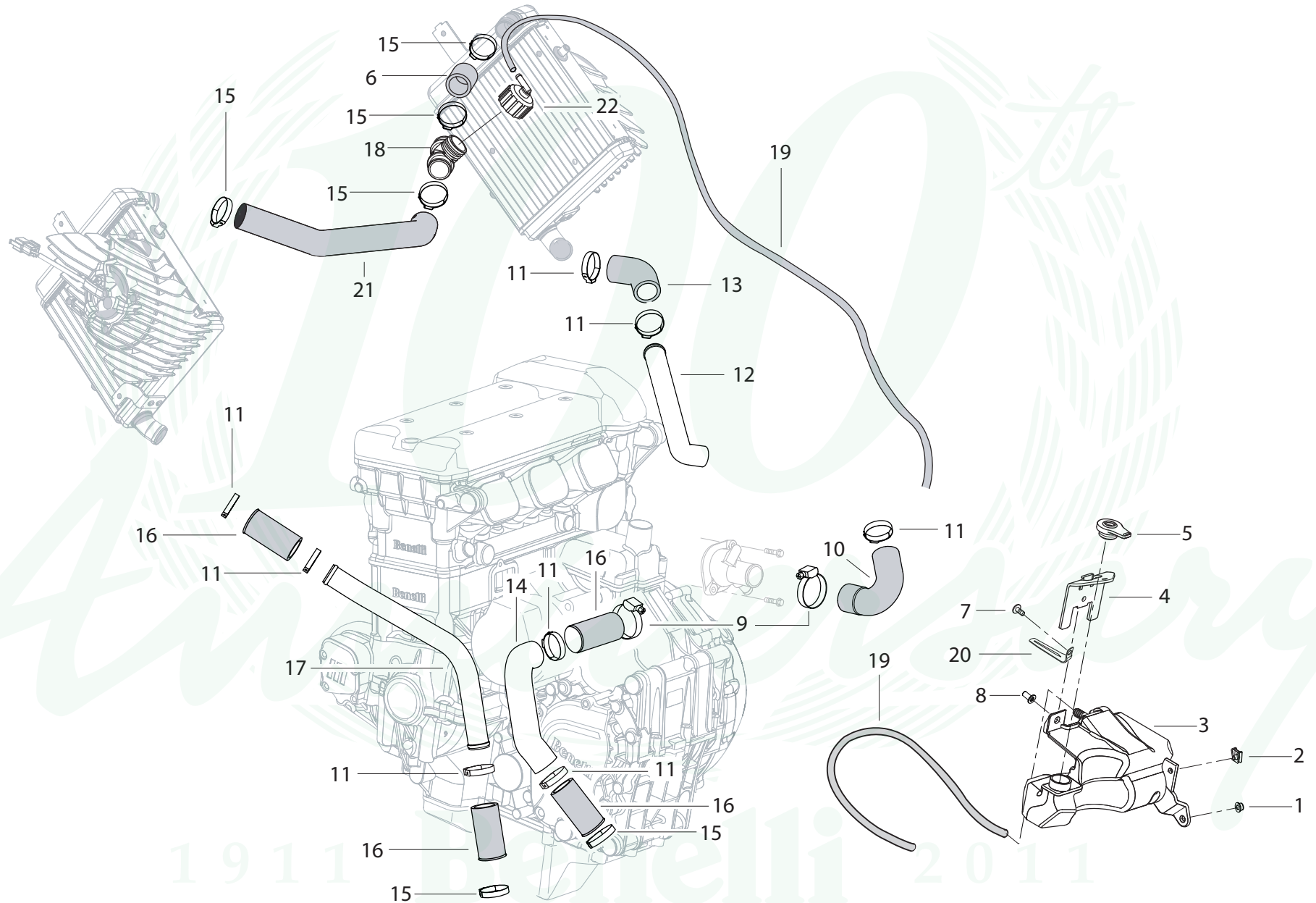

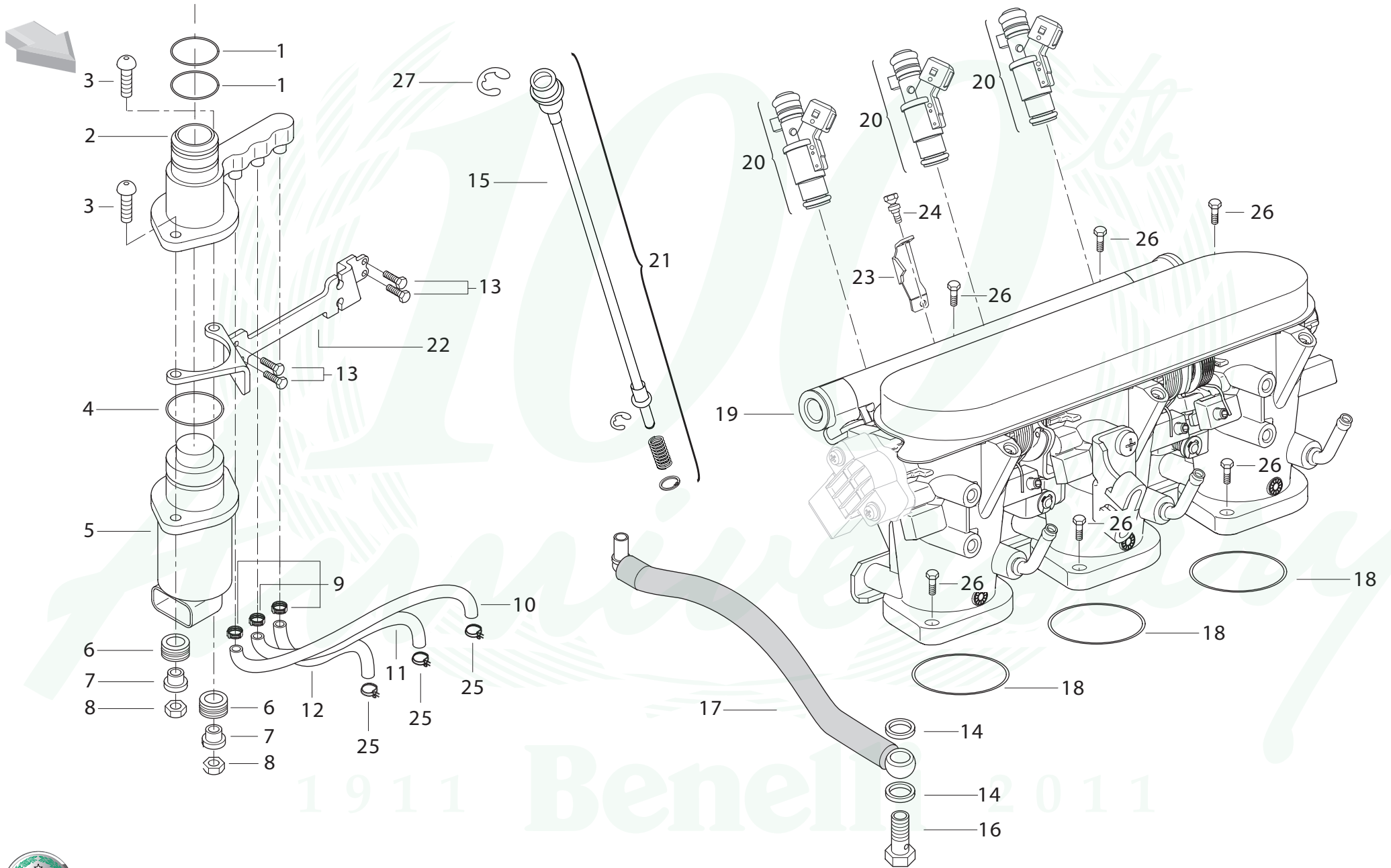

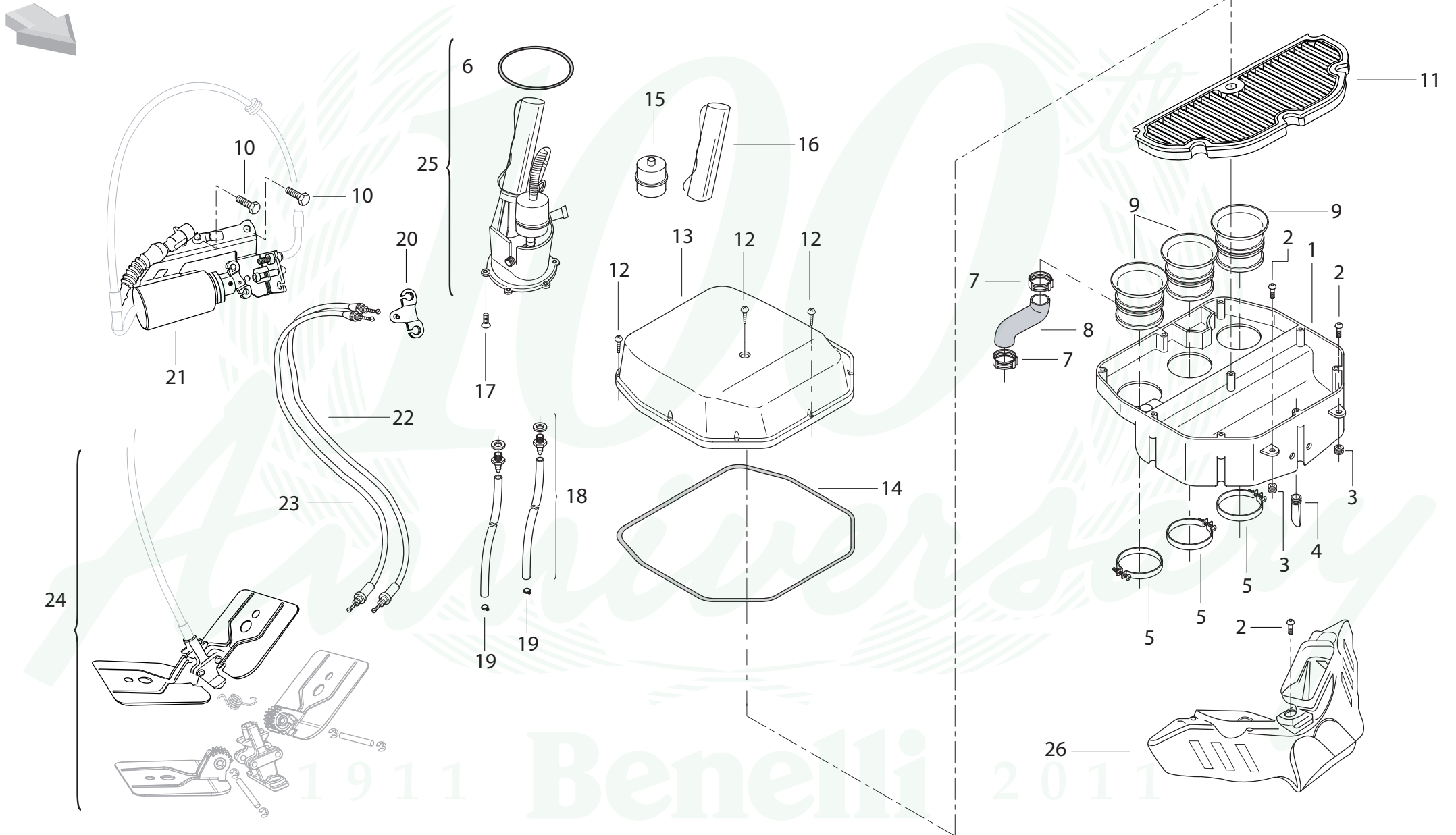

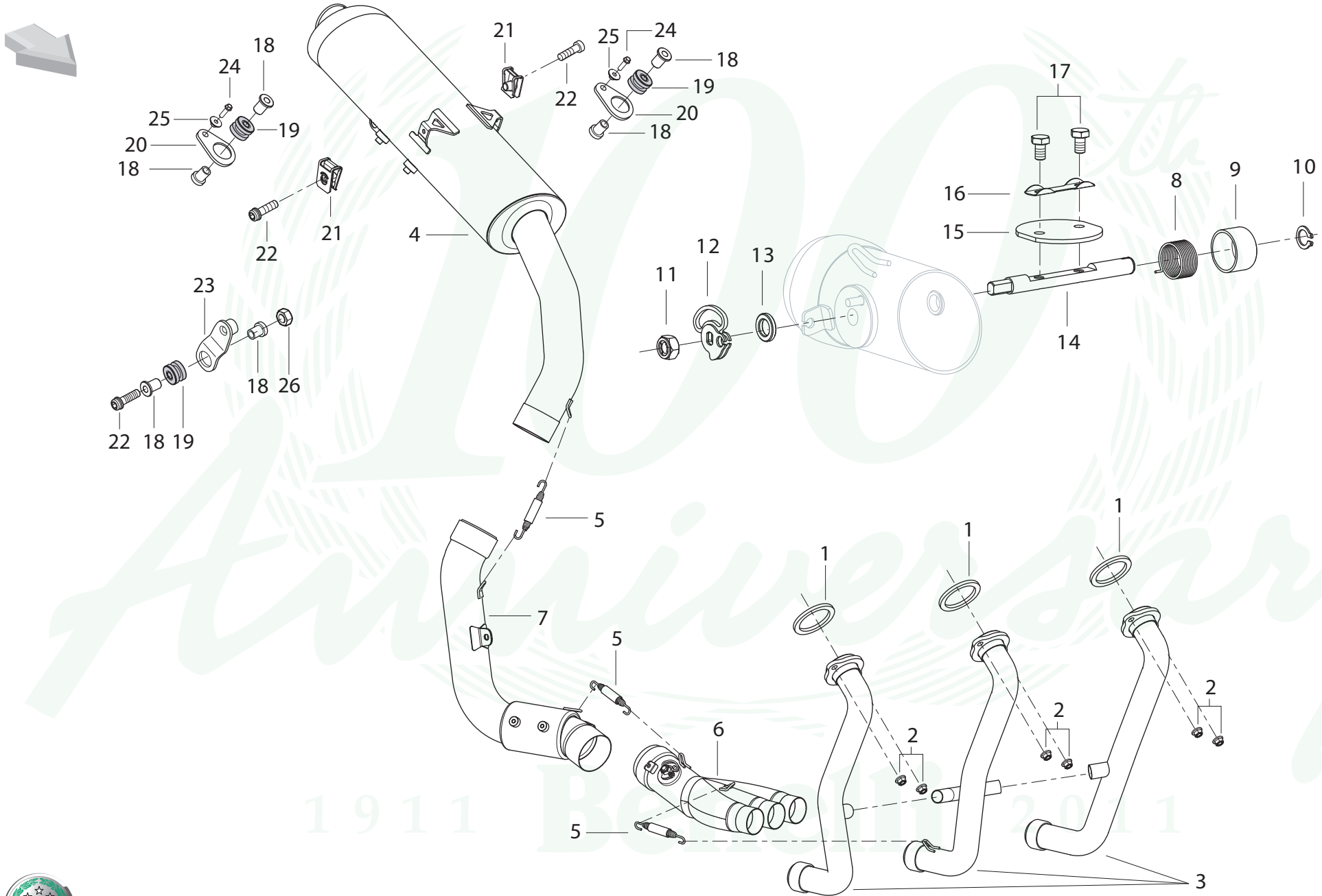

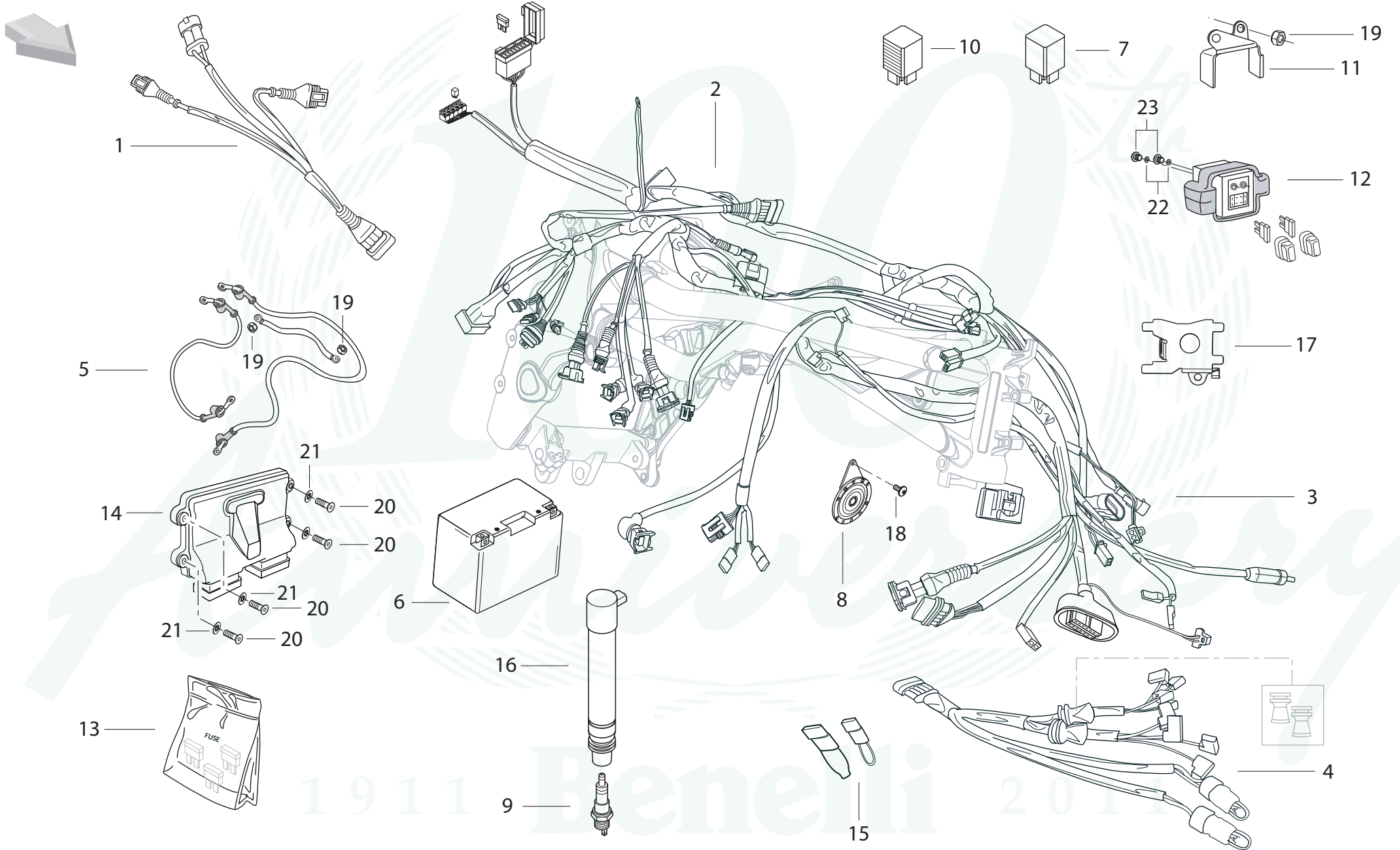

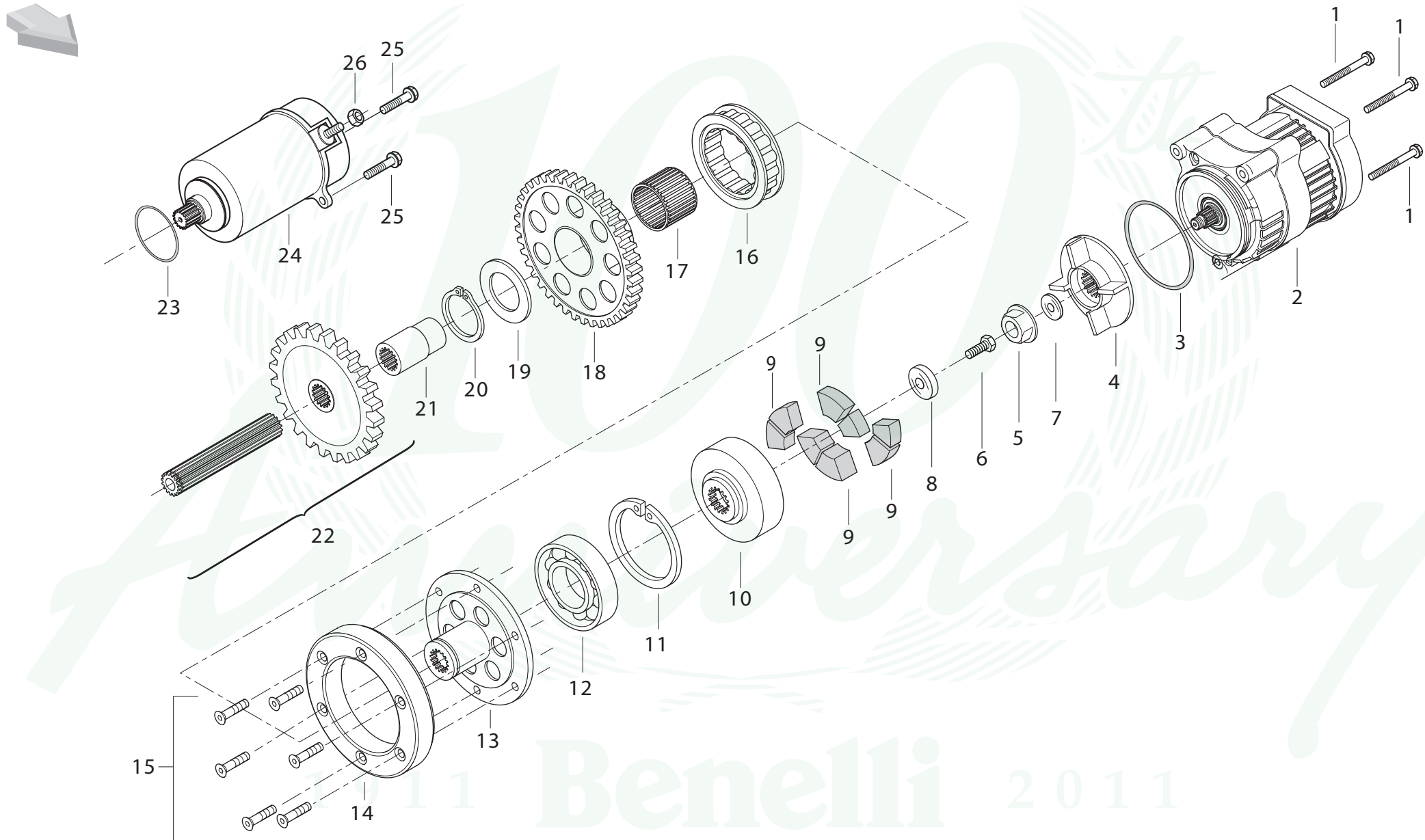

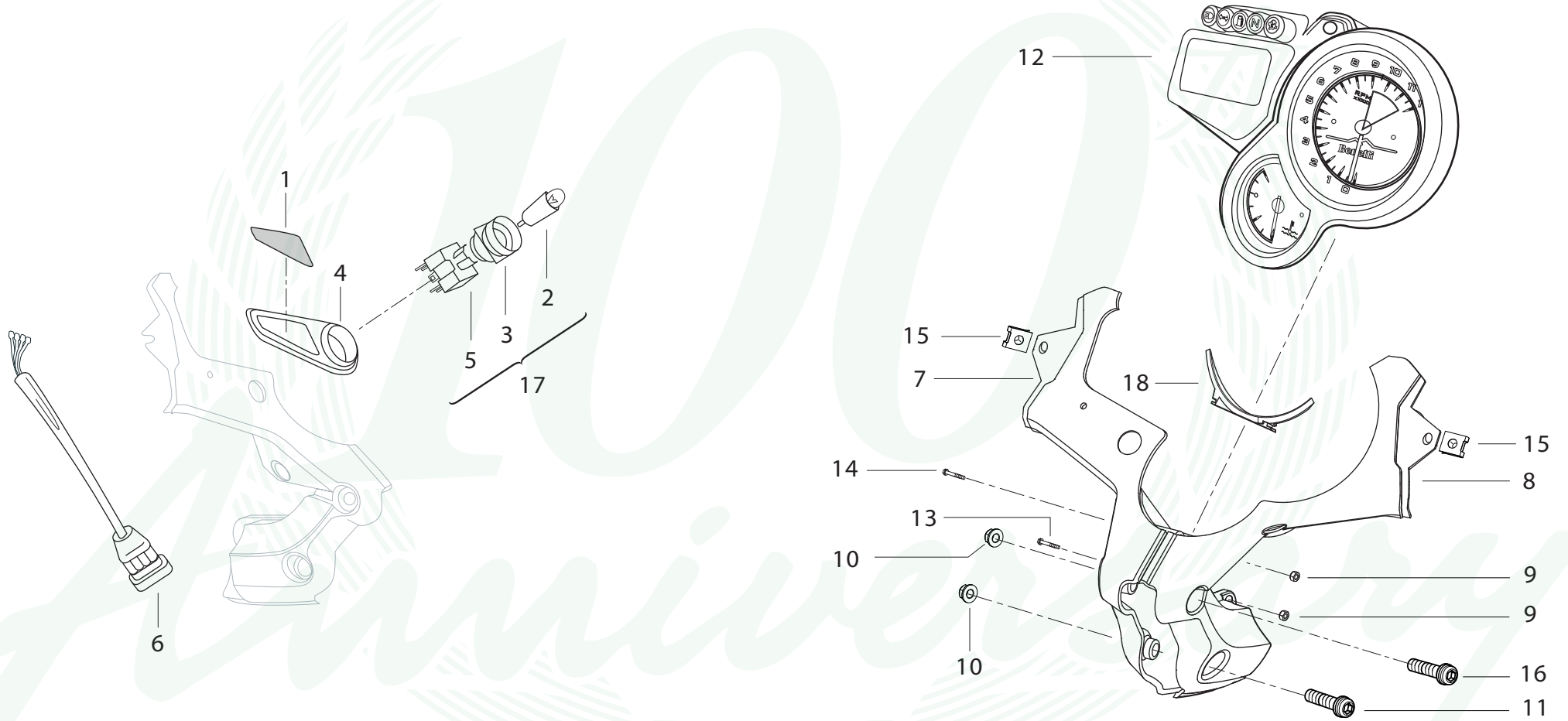

1911 Benelli 2011

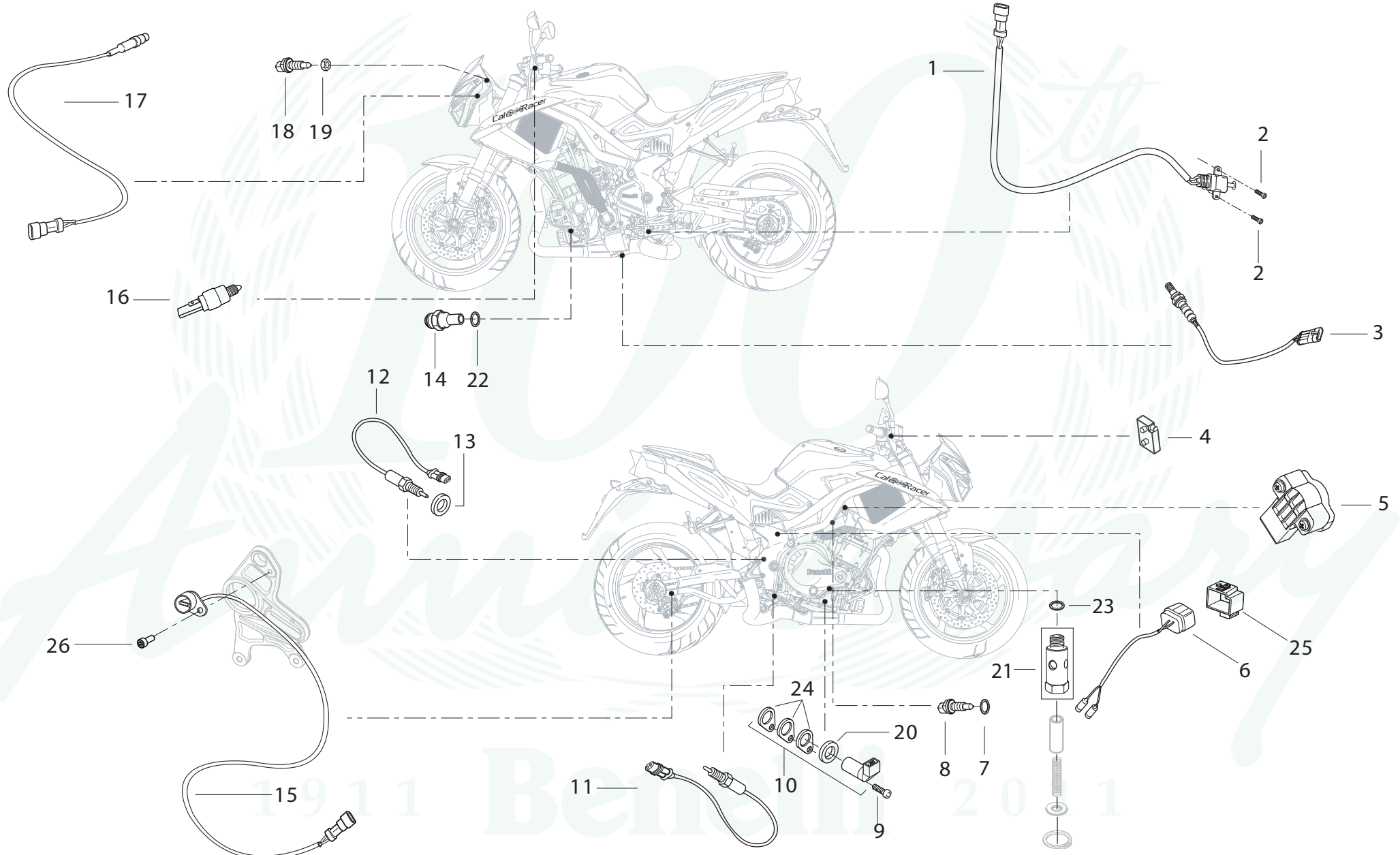

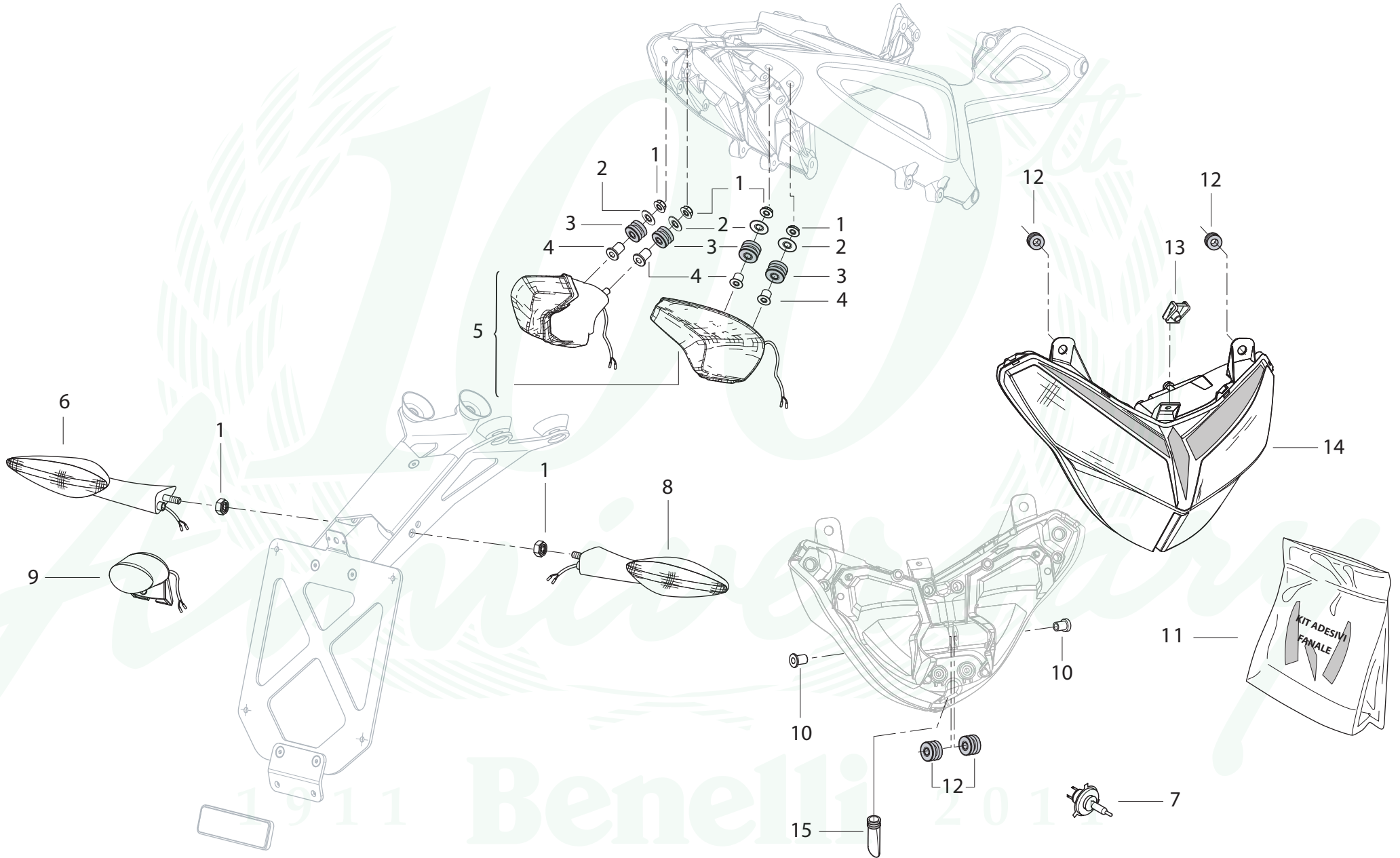

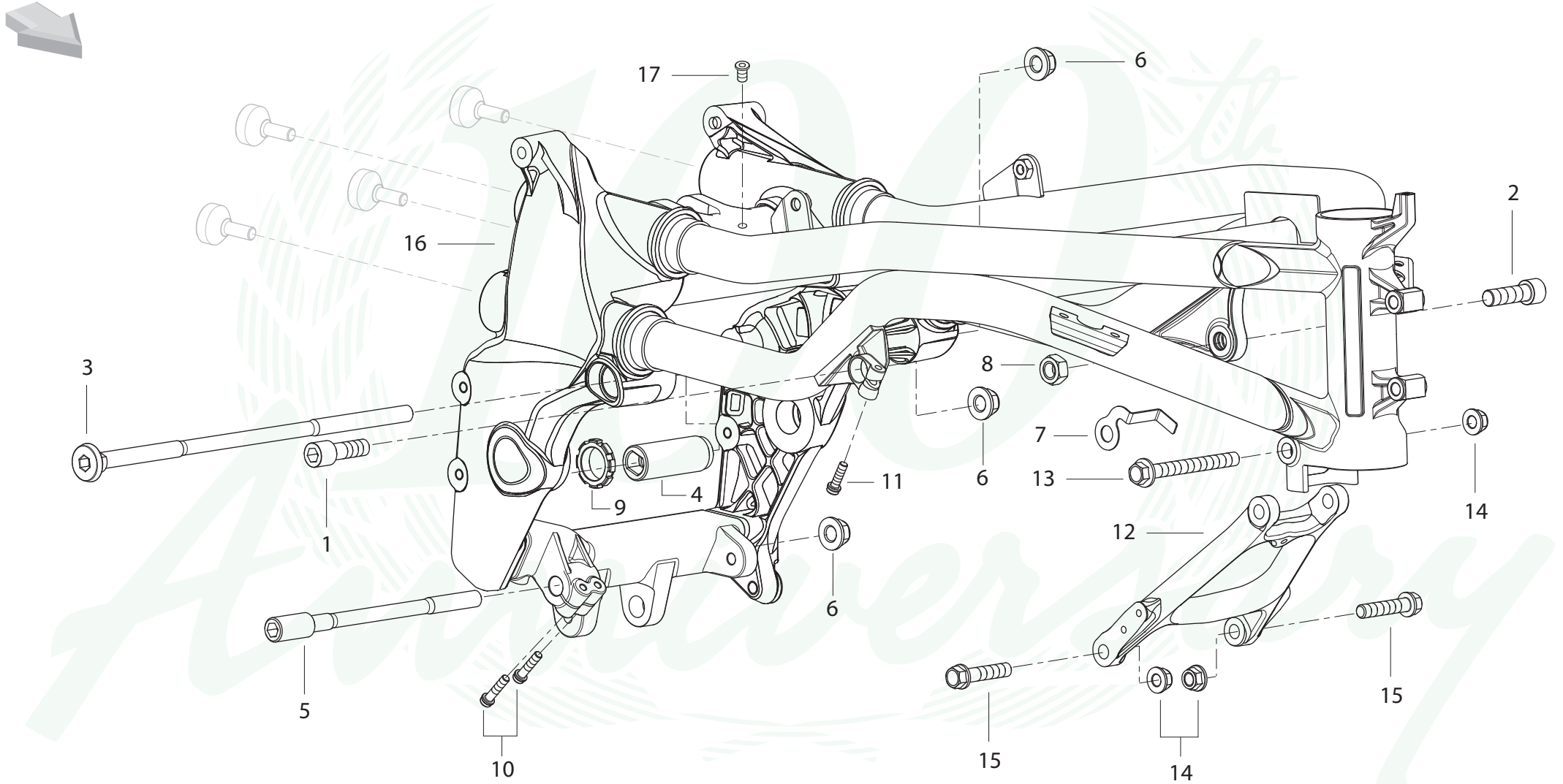

1911 Benelli 2011



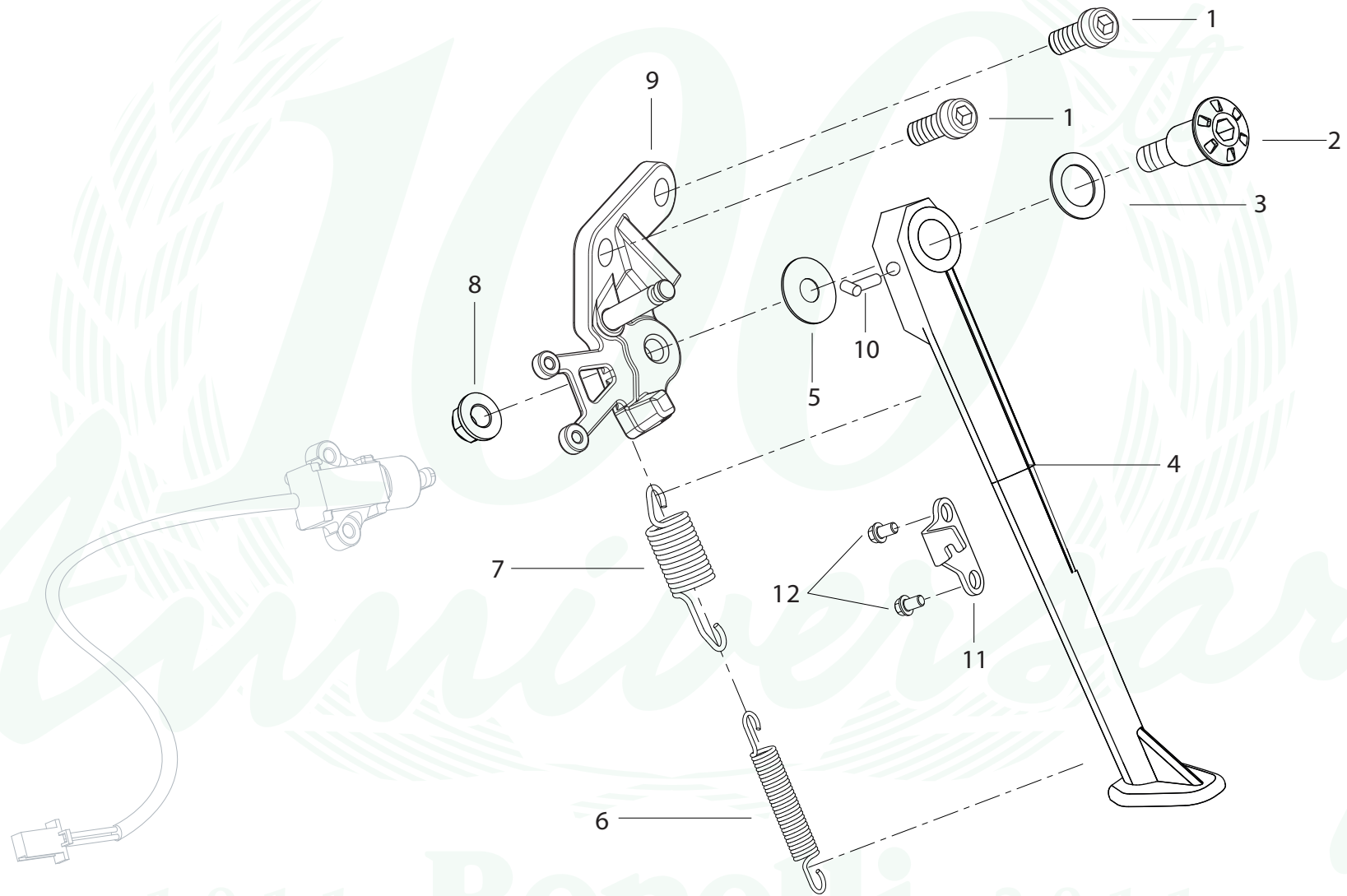

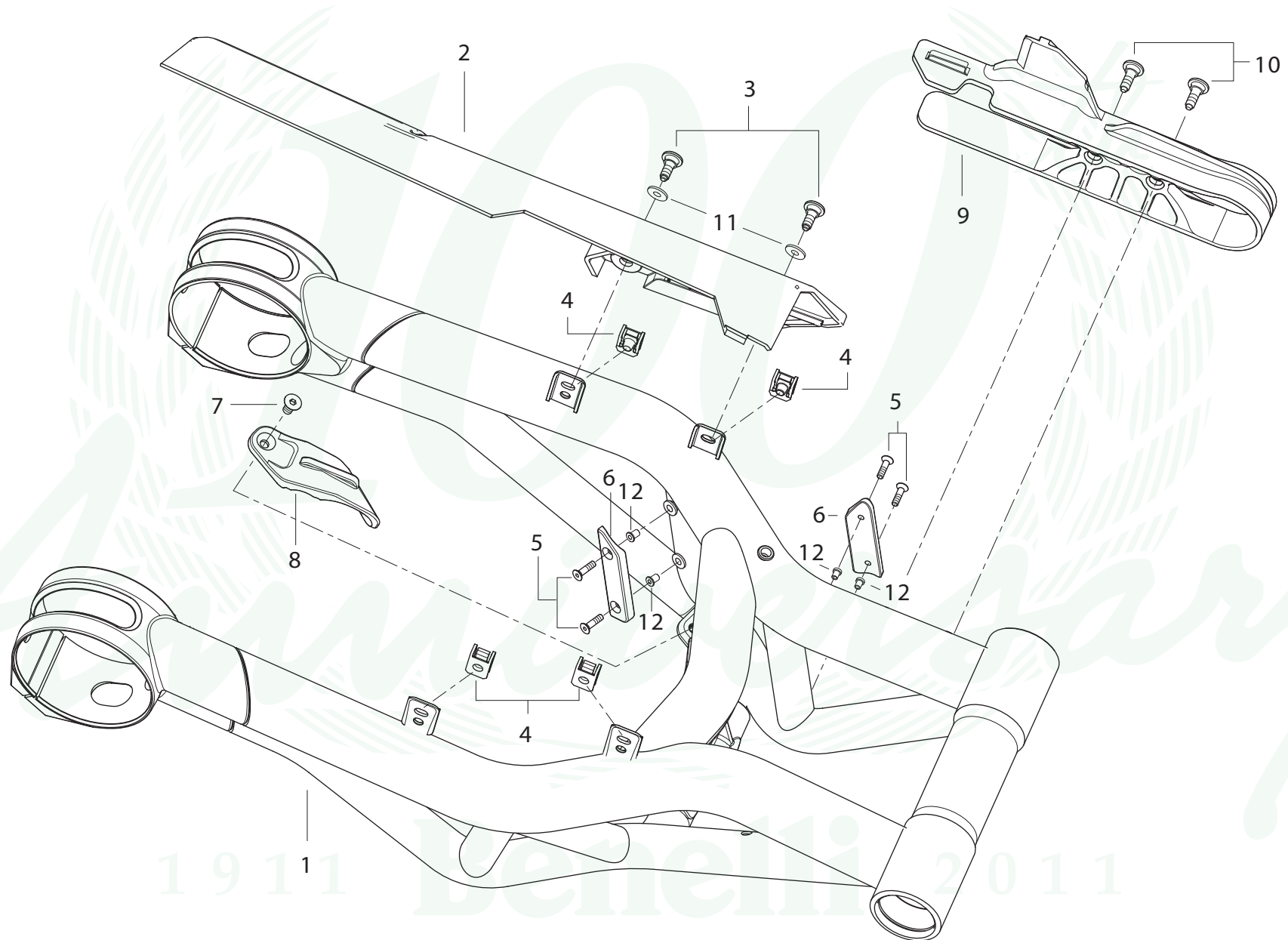



ASSIEME FORCELLONE



SWING ARM ASSEMBLY



ENSEMBLE FOURCHE



GABEL KOMPLETT



GRUPO BASCULANTE

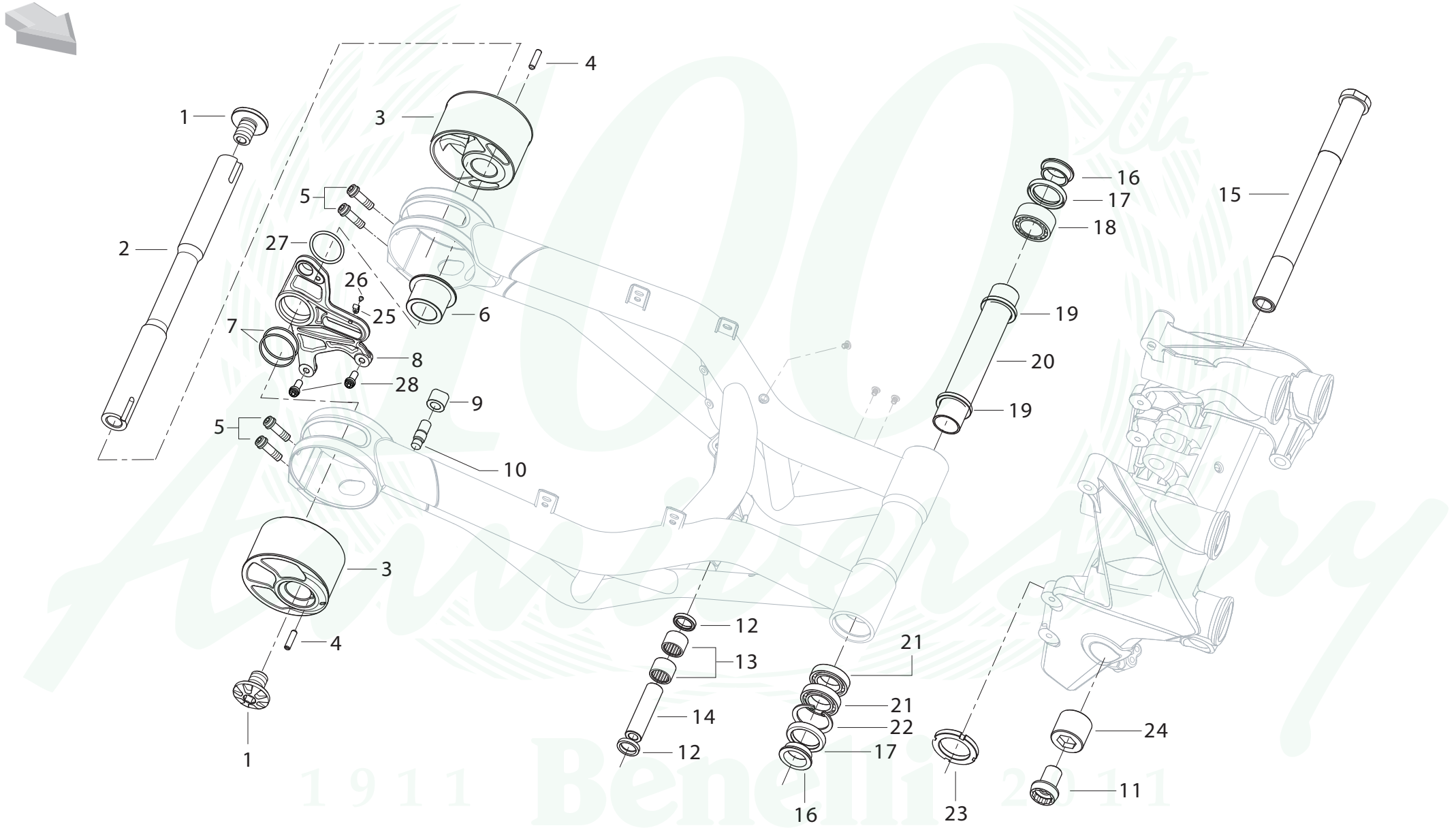

SOSPENSIONE POSTERIORE

🇮🇹 SOSPENSIONE POSTERIORE

🇬🇧 REAR SUSPENSION

🇫🇷 SUSPENSION ARRIÈRE

🇩🇪 HINTERRADFEDERUNG

🇪🇸 SUSPENSION TRASERA

TAVOLA
DRAWING
TABLE
BILD
TABLA

027

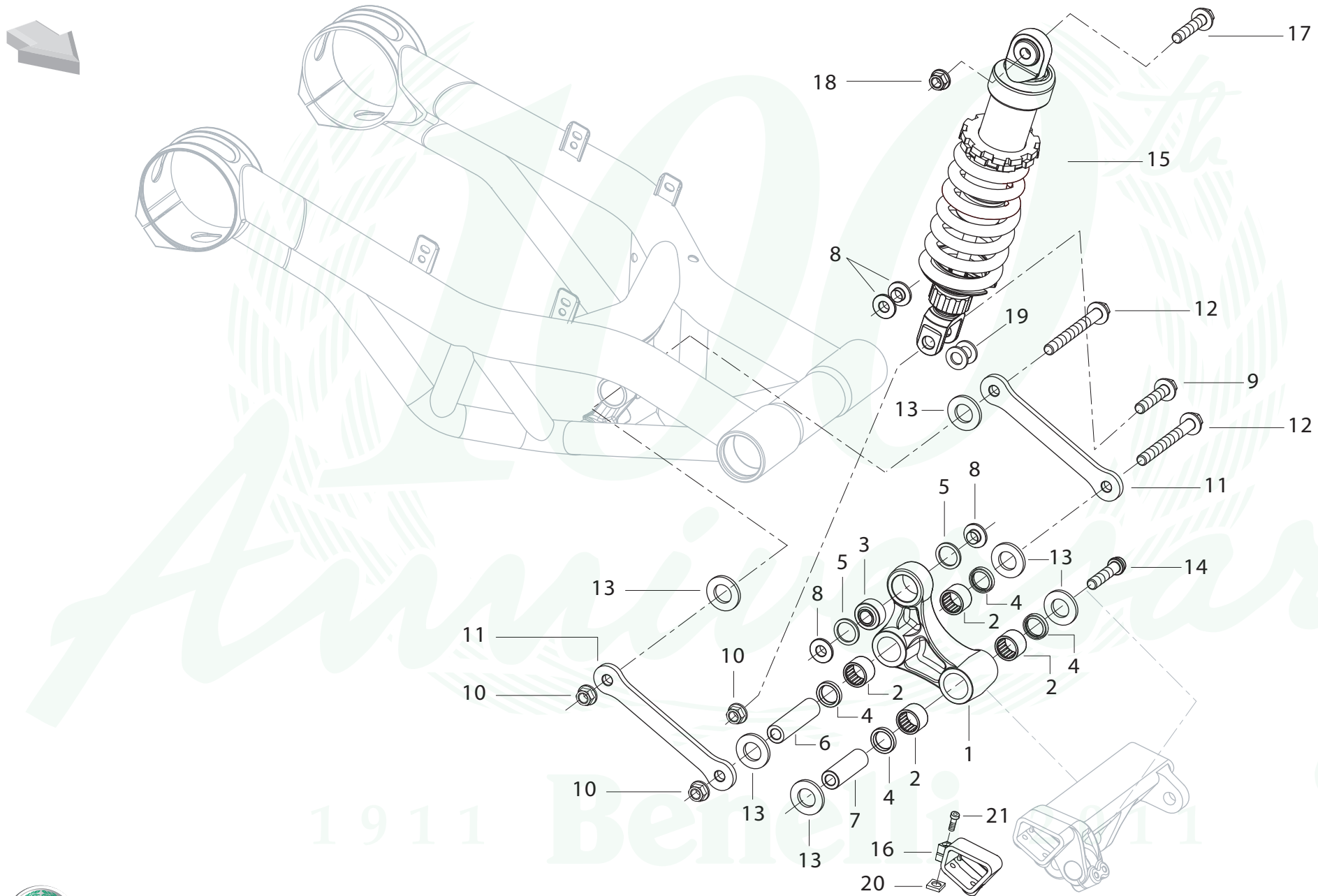

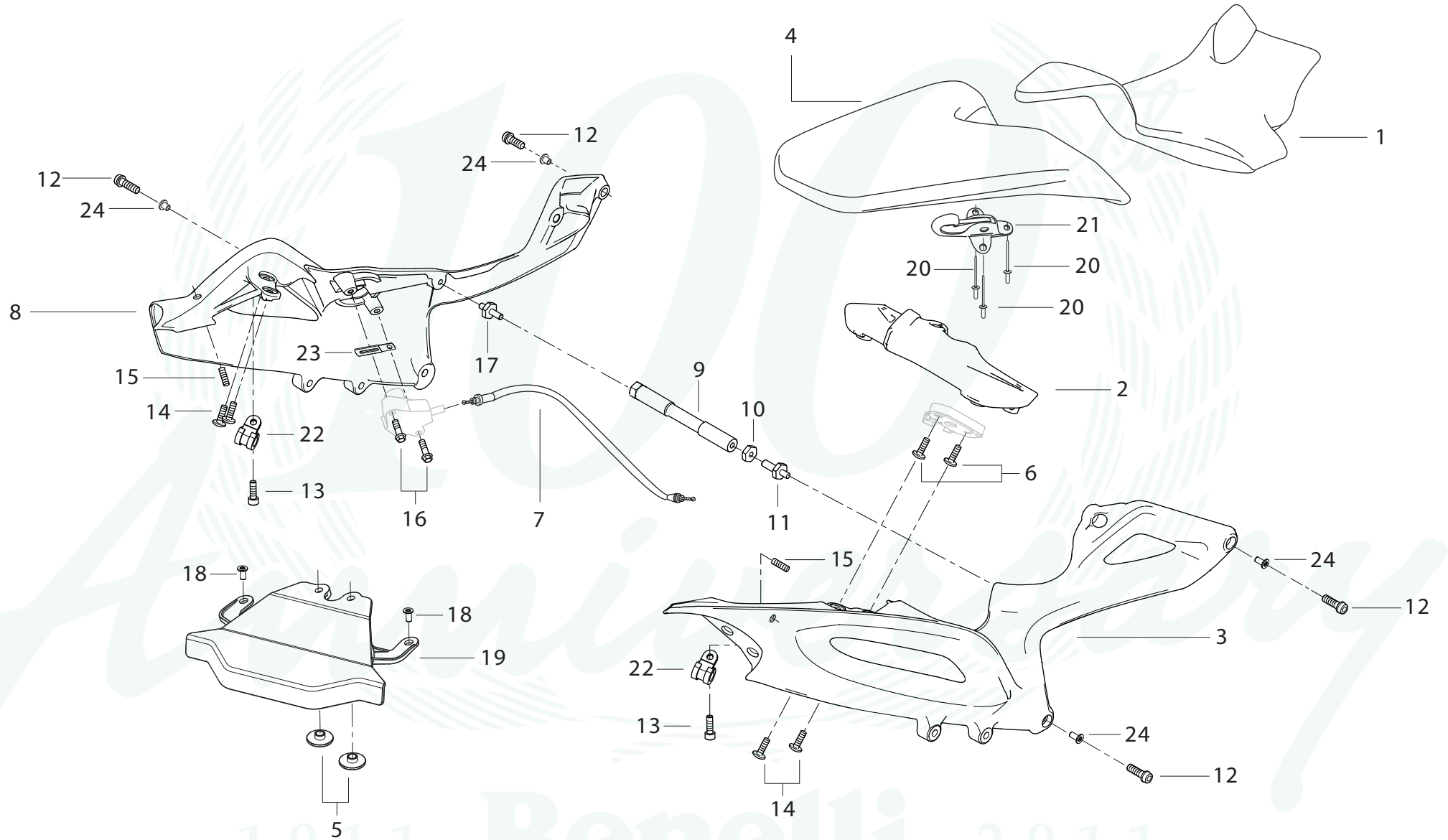

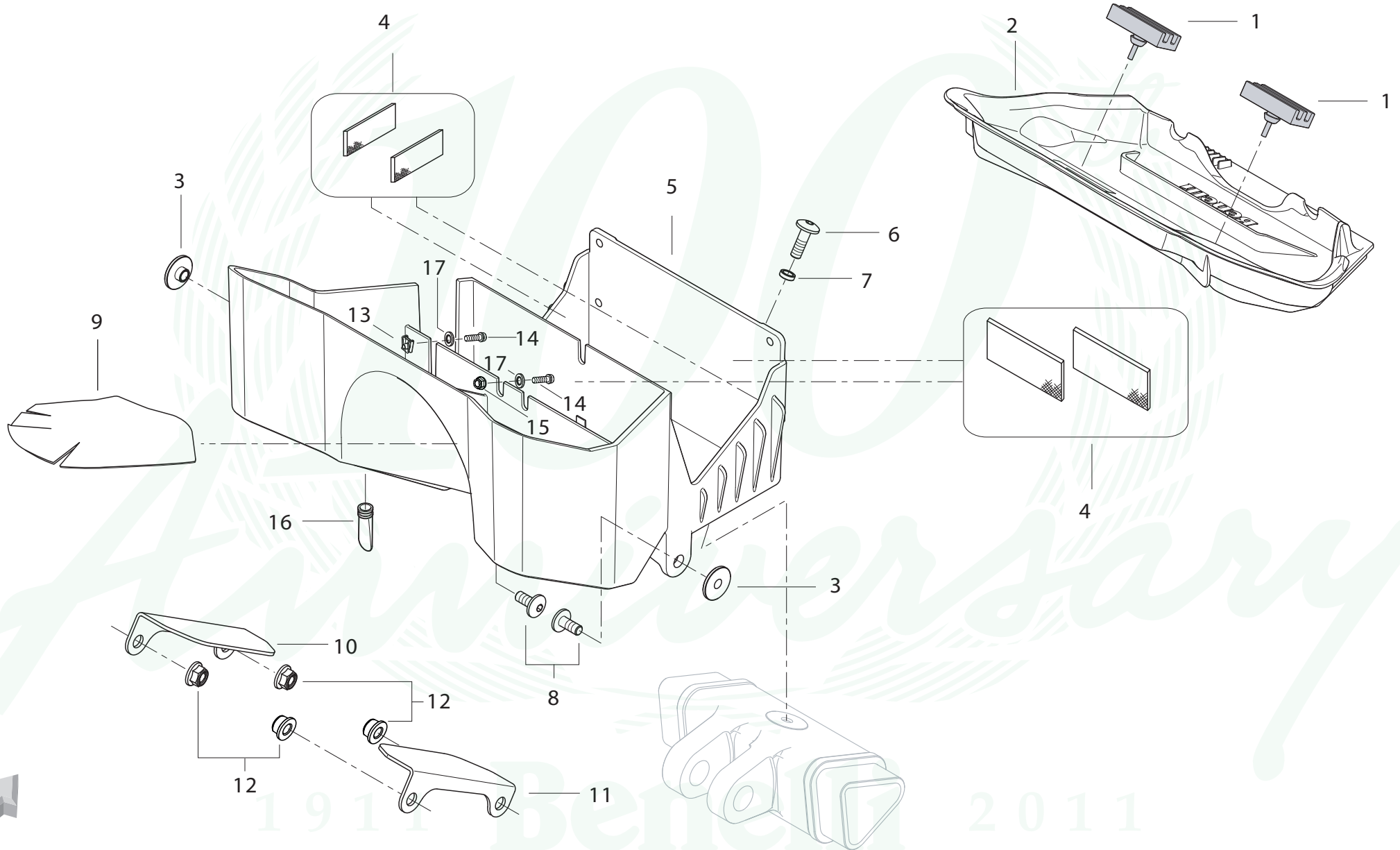

PORTATARGA

PORTATARGA

NUMBER PLATE HOLDER

PORTE-PLAQUE

NUMMERSCHILDTAFEL

PORTA-MATRÍCULA

TAVOLA
DRAWING
TABLE
BILD
TABLA

030

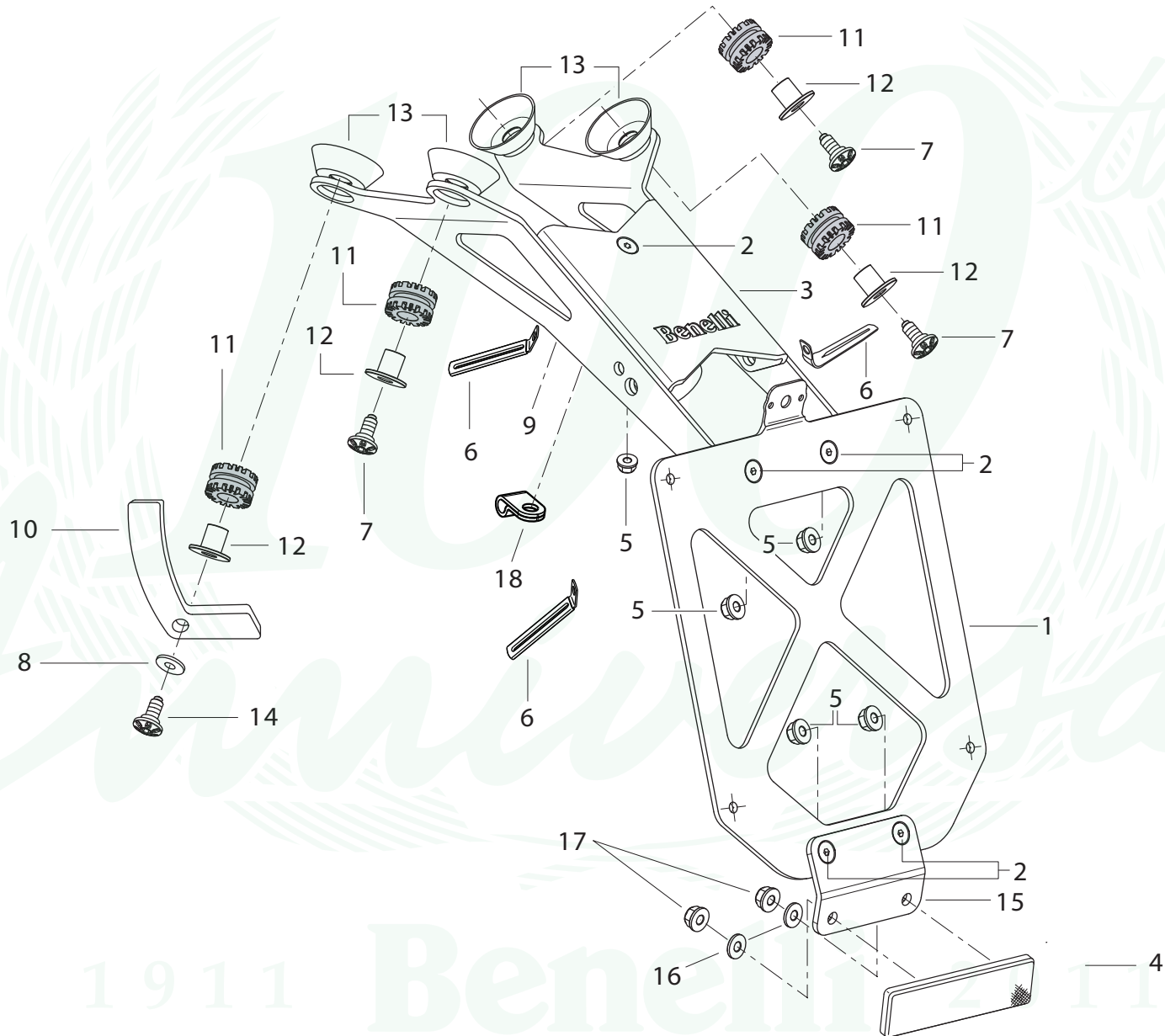

PEDANE ANTERIORI



PEDANE ANTERIORI



FRONT FOOT PEG



REPOSE PIEDS AVANT



VORDERE FUSSRASTE



ESTRIBERAS DELANTERA

TAVOLA
DRAWING
TABLE
BILD
TABLA

031

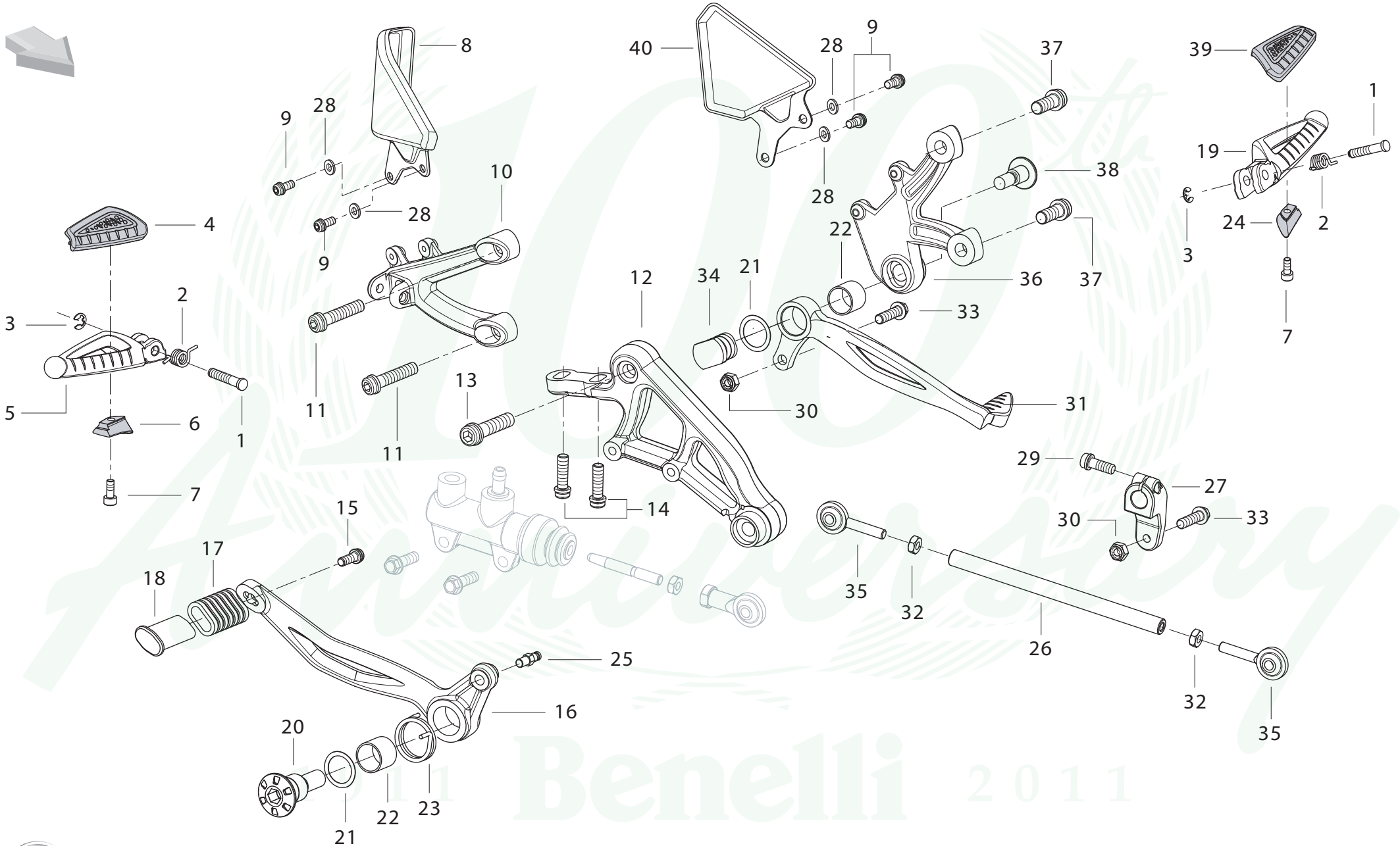

Benelli 2011

PEDANE POSTERIORI

 PEDANE POSTERIORI

 REAR FOOT PEG

 REPOSE PIED ARRIÈRE

 HINTERE FUSSRASTE

 ESTRIBERAS TRASERA

TAVOLA
DRAWING
TABLE
BILD
TABLA

032

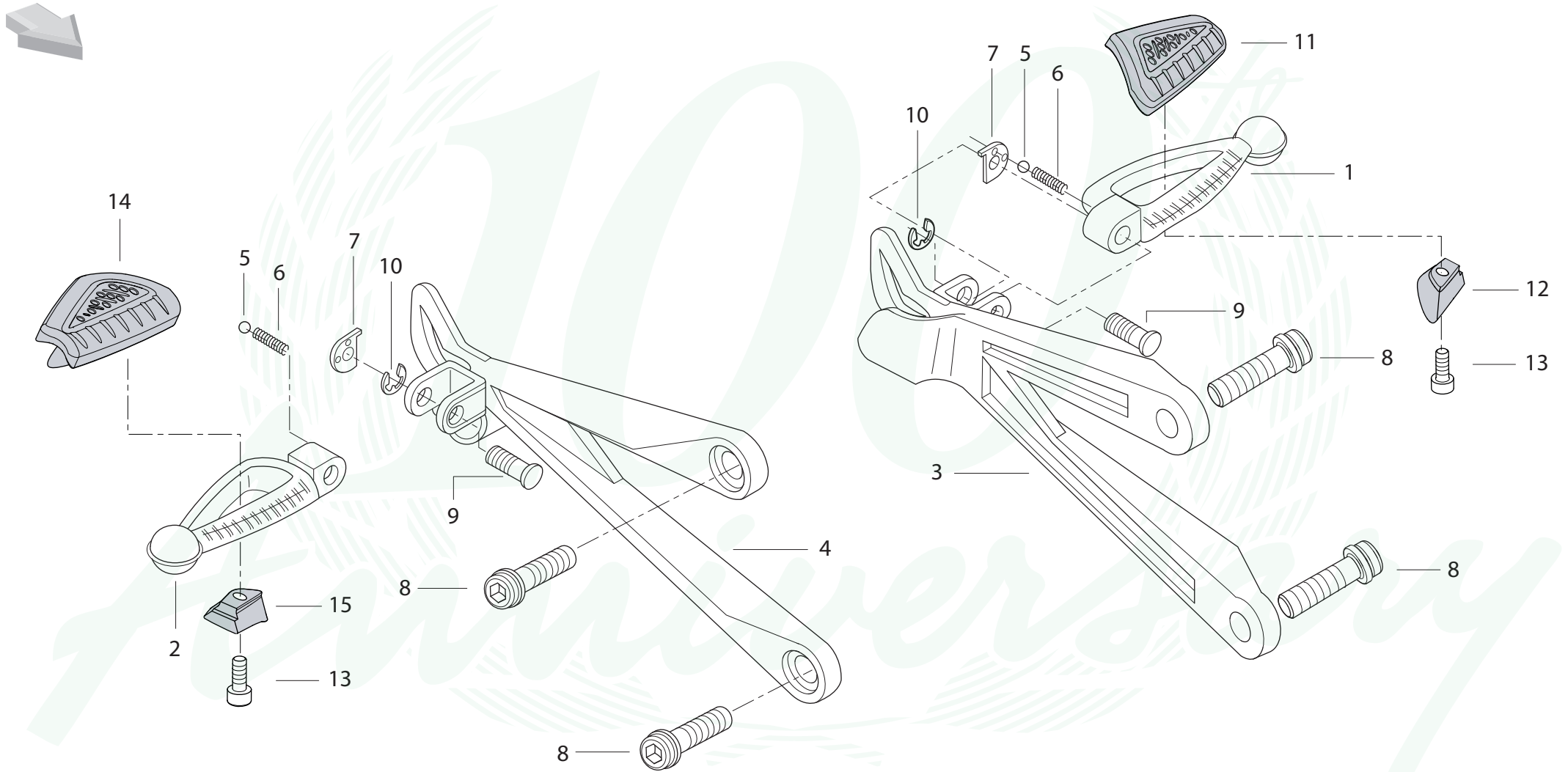

1911 Benelli 2011



PARAFANGO ANTERIORE

 PARAFANGO ANTERIORE

 FRONT MUDGUARD

 GARDE-BOUE AVANT

 VORDERES SCHUTZBLECH

 GUARDABARROS DELANTERO

TAVOLA
DRAWING
TABLE
BILD
TABLA

033

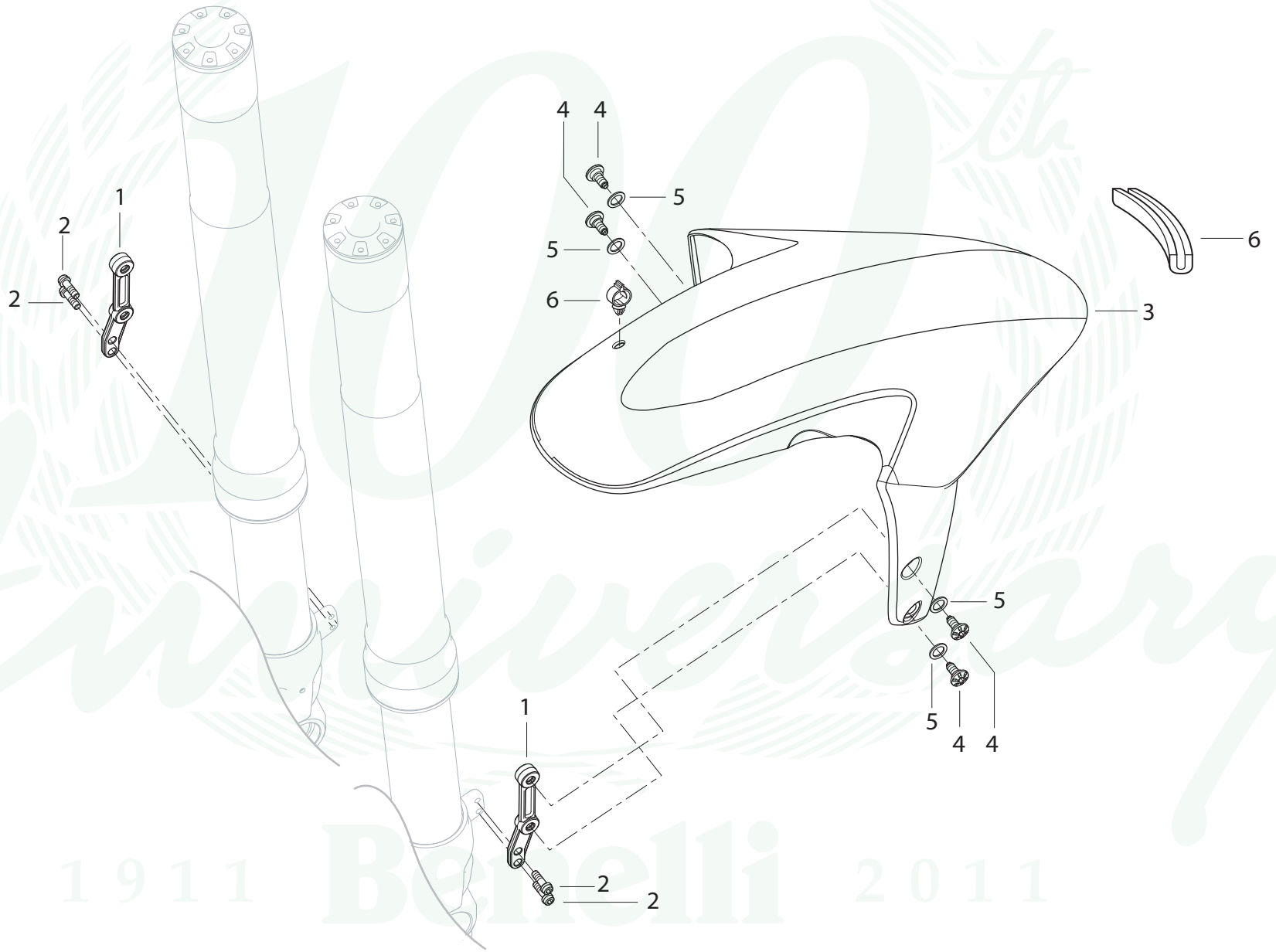

PARAFANGO POSTERIORE

PARAFANGO POSTERIORE

REAR MUDGUARD

GARDE-BOUE ARRIÈRE

HINTERE SCHUTZBLECH

GUARDABARROS TRASERO

TAVOLA
DRAWING
TABLE
BILD
TABLA

034

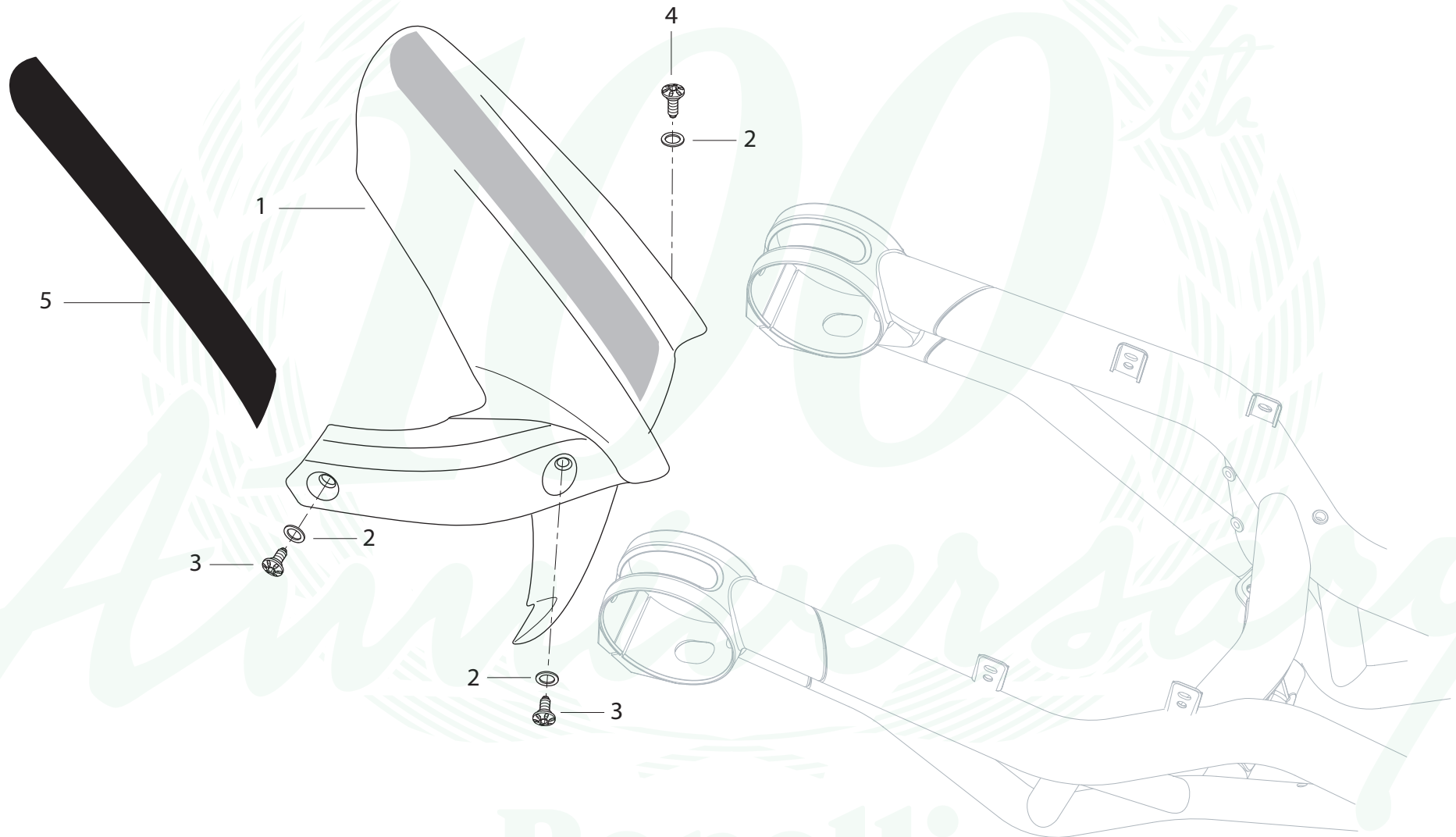

1911

Benelli

2011



FORCELLA ANTERIORE

FORCELLA ANTERIORE

FRONT FORK

FOURCHE AVANT

TELEGABEL

HORQUILLA DELANTERA

TAVOLA
DRAWING
TABLE
BILD
TABLA

035

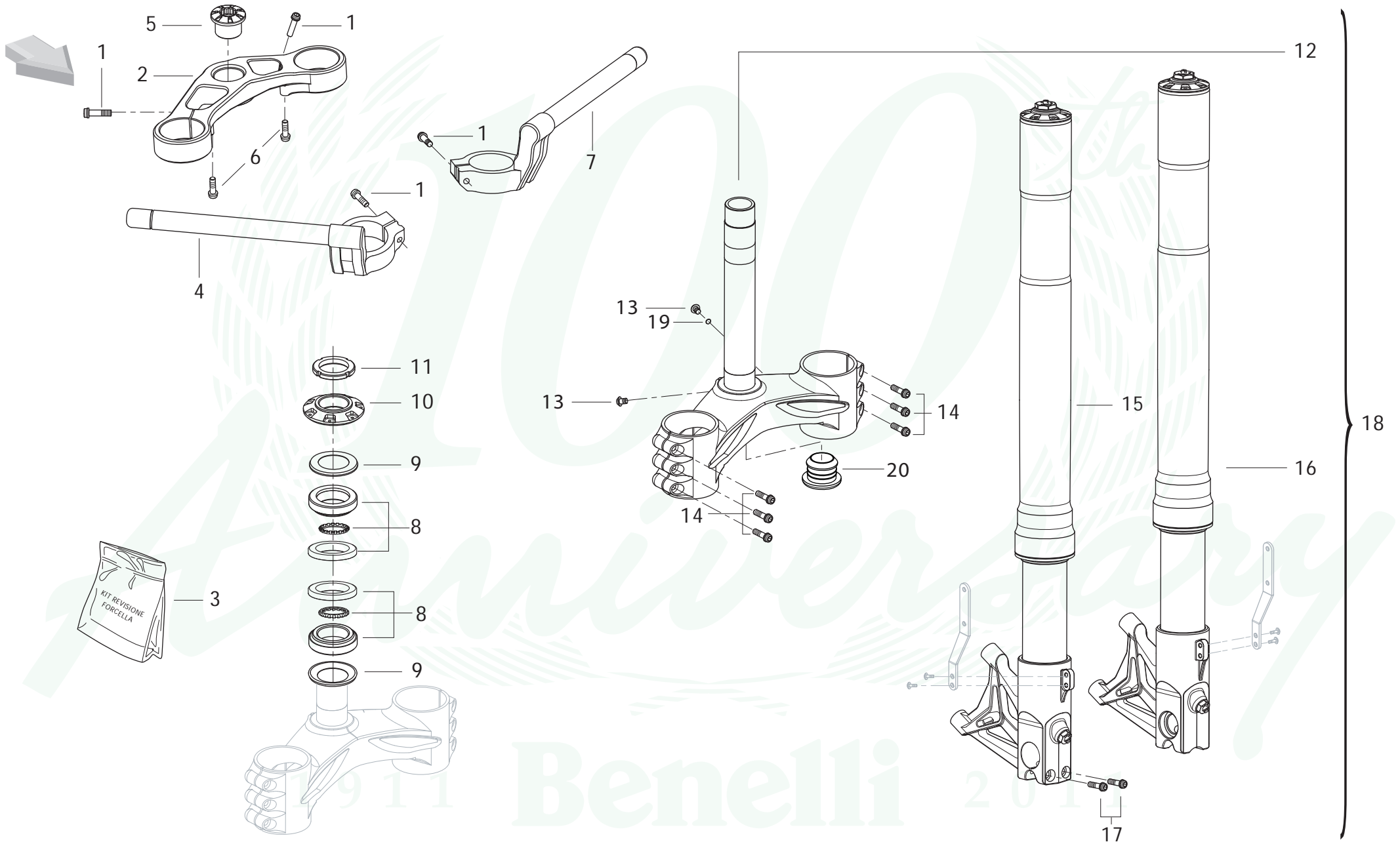

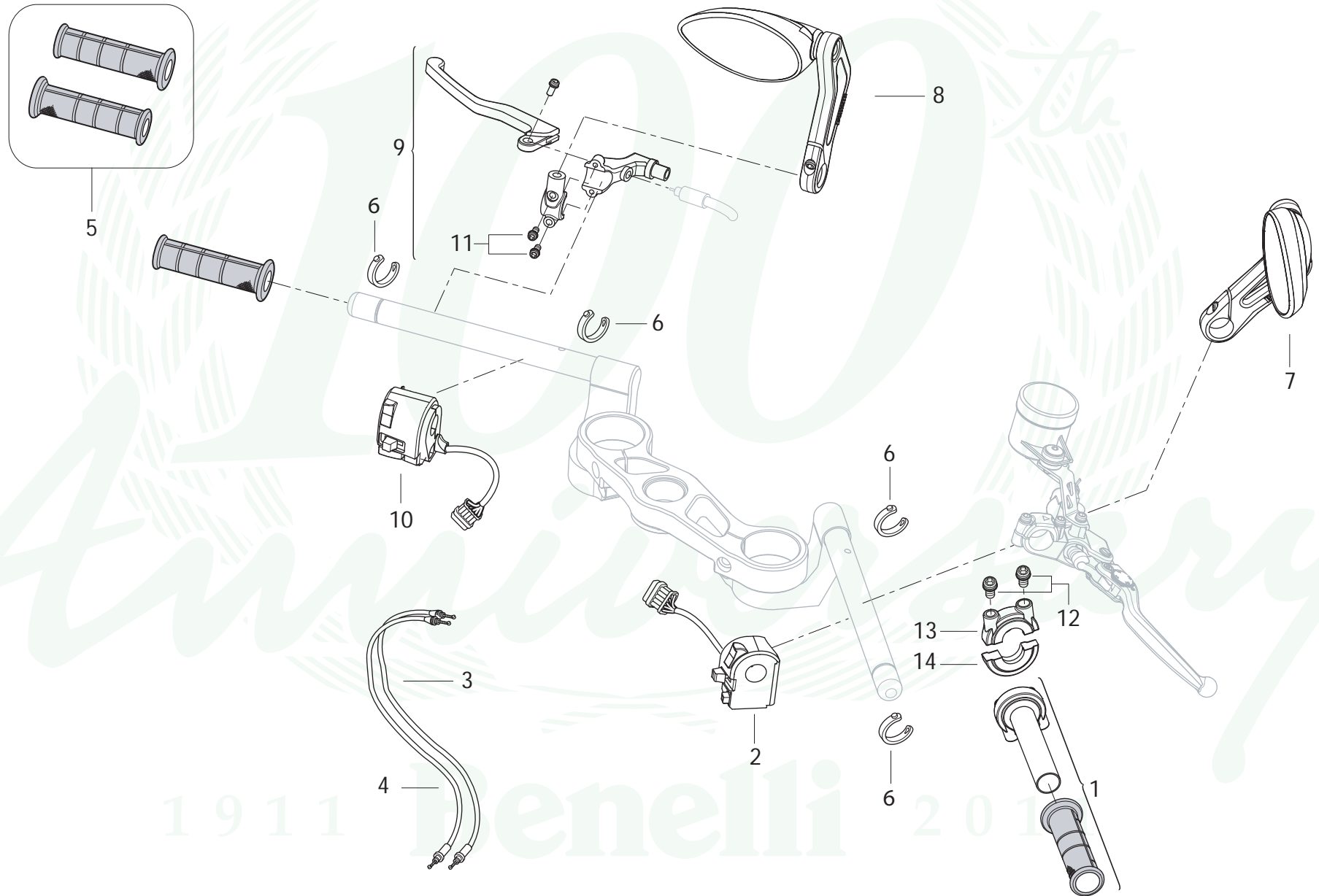

FRENO ANTERIORE

 FRENO ANTERIORE

 FRONT BRAKE

 FREIN AVANT

 VORD BREMSE

 FRENO DELANTERO

TAVOLA
DRAWING
TABLE
BILD
TABLA

037



1911 Benelli 2011

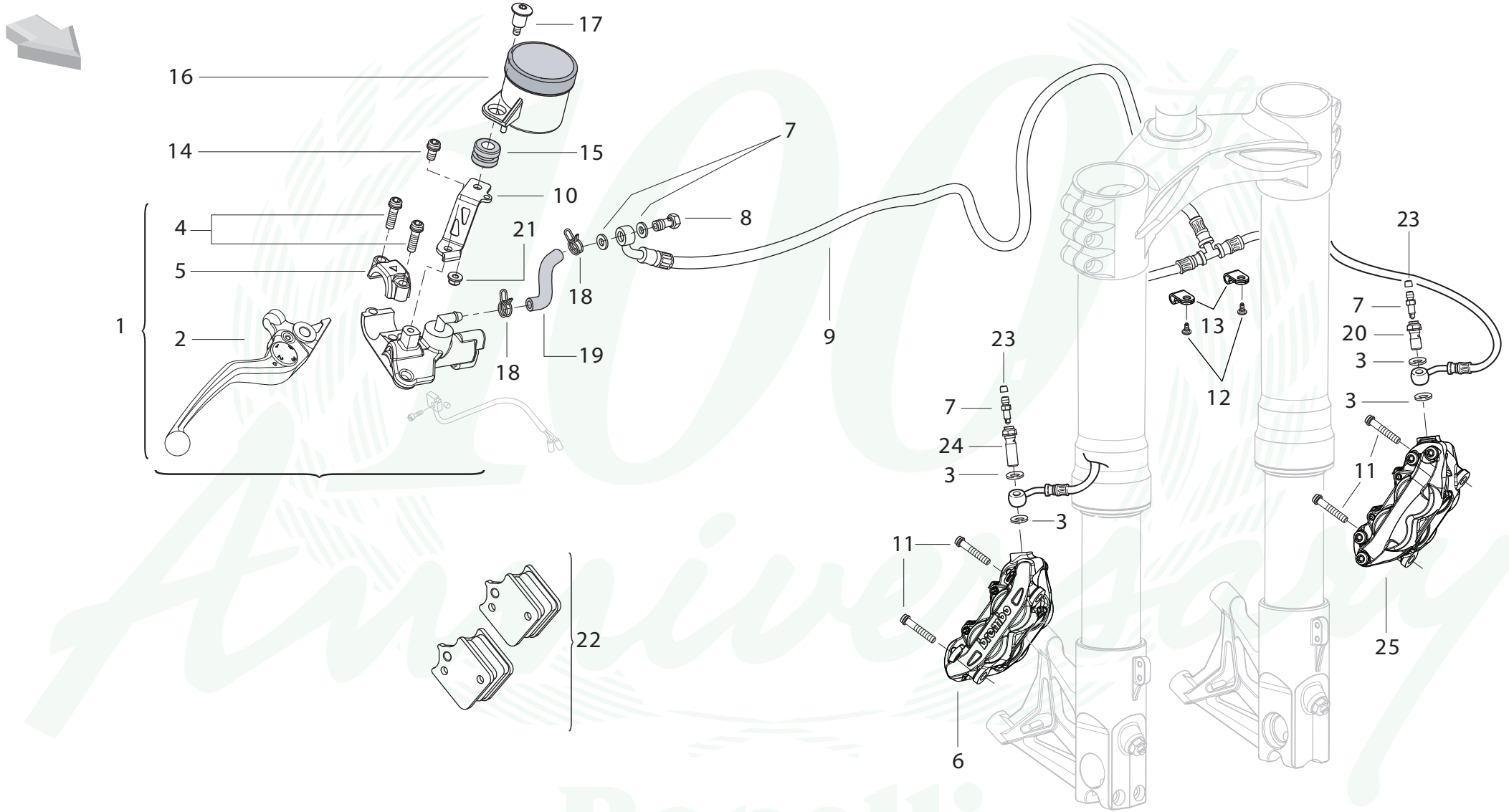

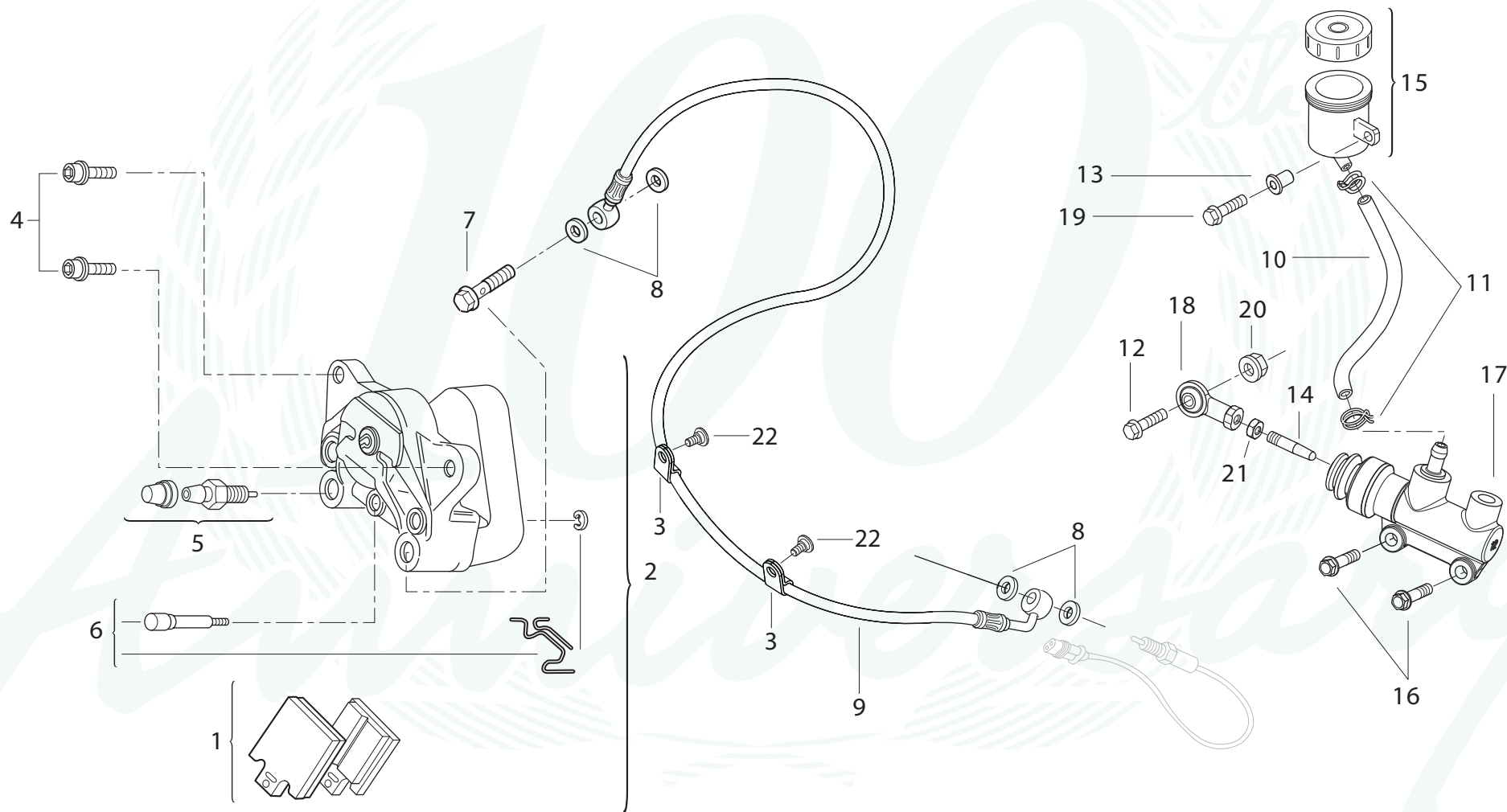

1911 Benelli 2011



RUOTA ANTERIORE

 RUOTA ANTERIORE

 FRONT WHELL

 ROUE AVANT

 VORDERRAD

 RUEDA DELANTERA

TAVOLA
DRAWING
TABLE
BILD
TABLA

039

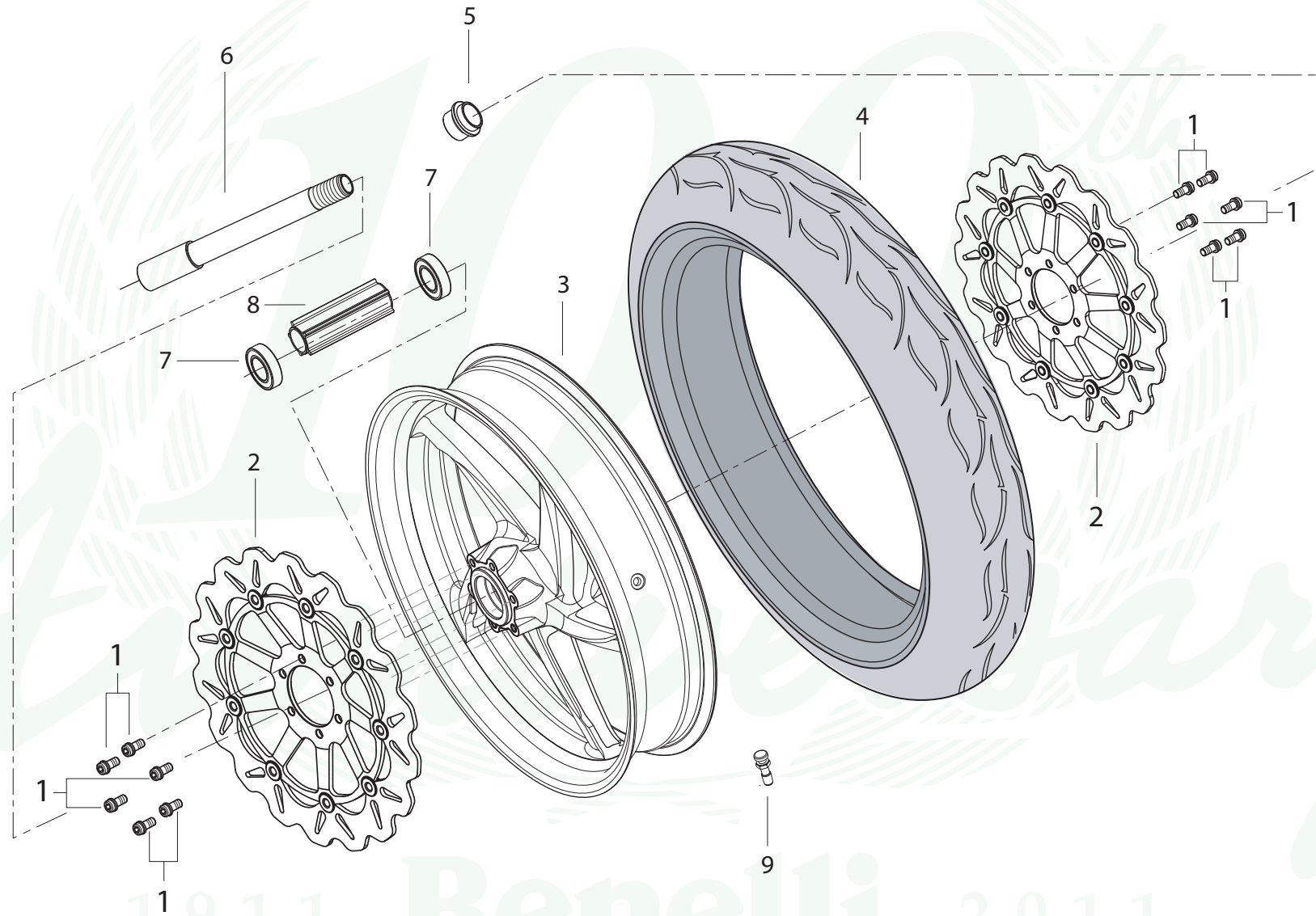

1911 Benelli 2011



RUOTA POSTERIORE

 RUOTA POSTERIORE

 REAR WHEEL

 ROUE ARRIÈRE

 HINTERRAD

 RUEDA TRASERA

TAVOLA
DRAWING
TABLE
BILD
TABLA

040

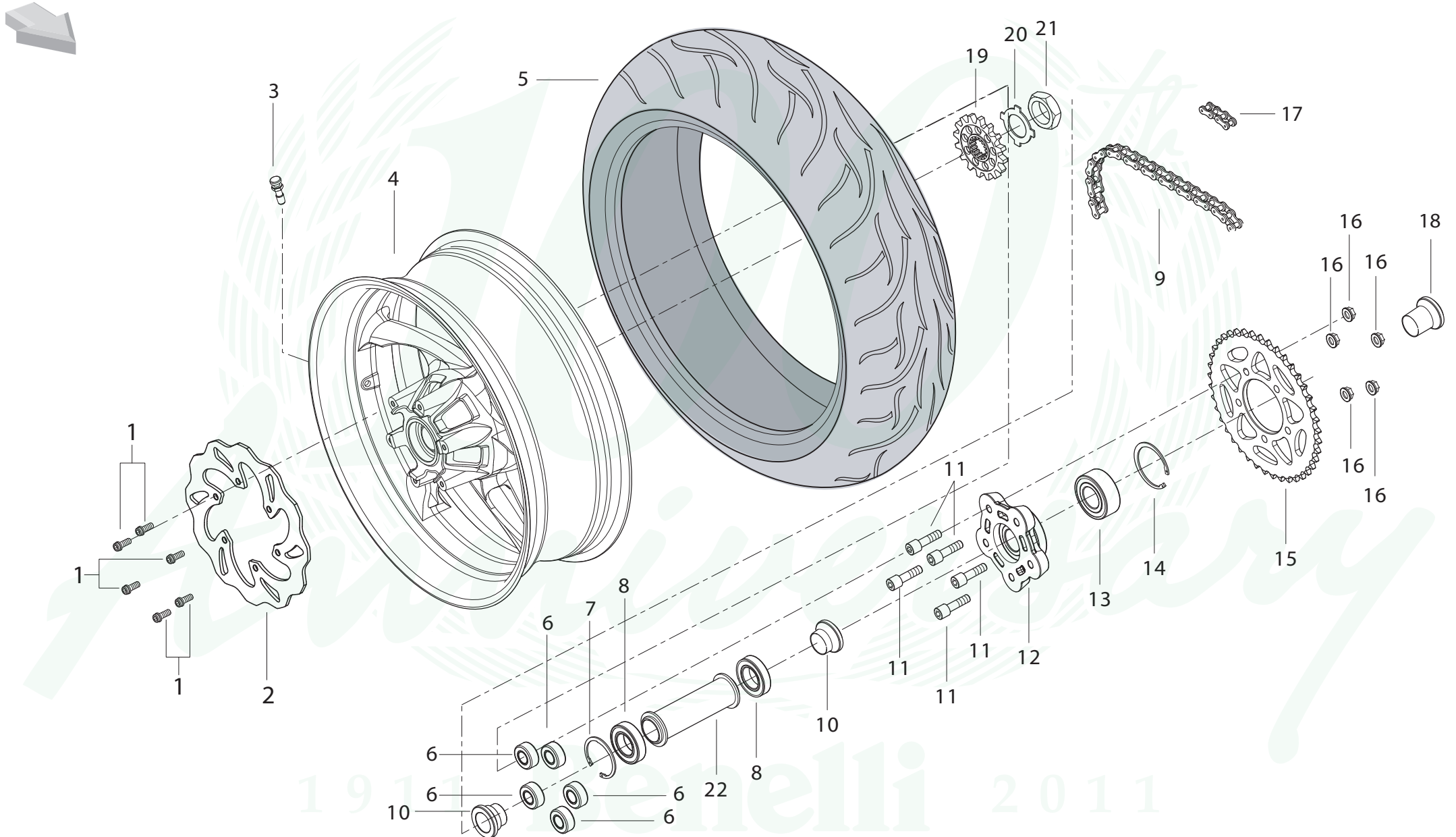

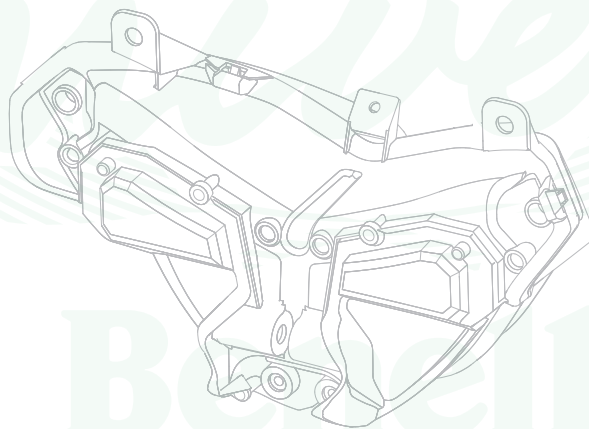
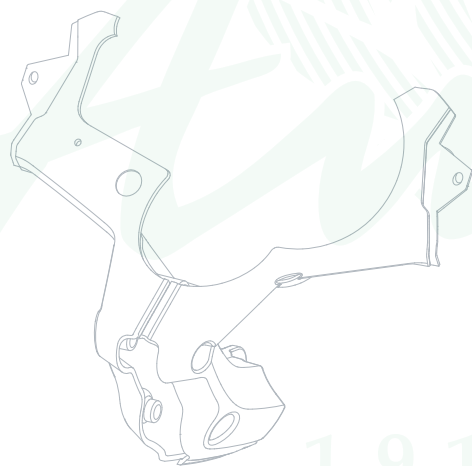
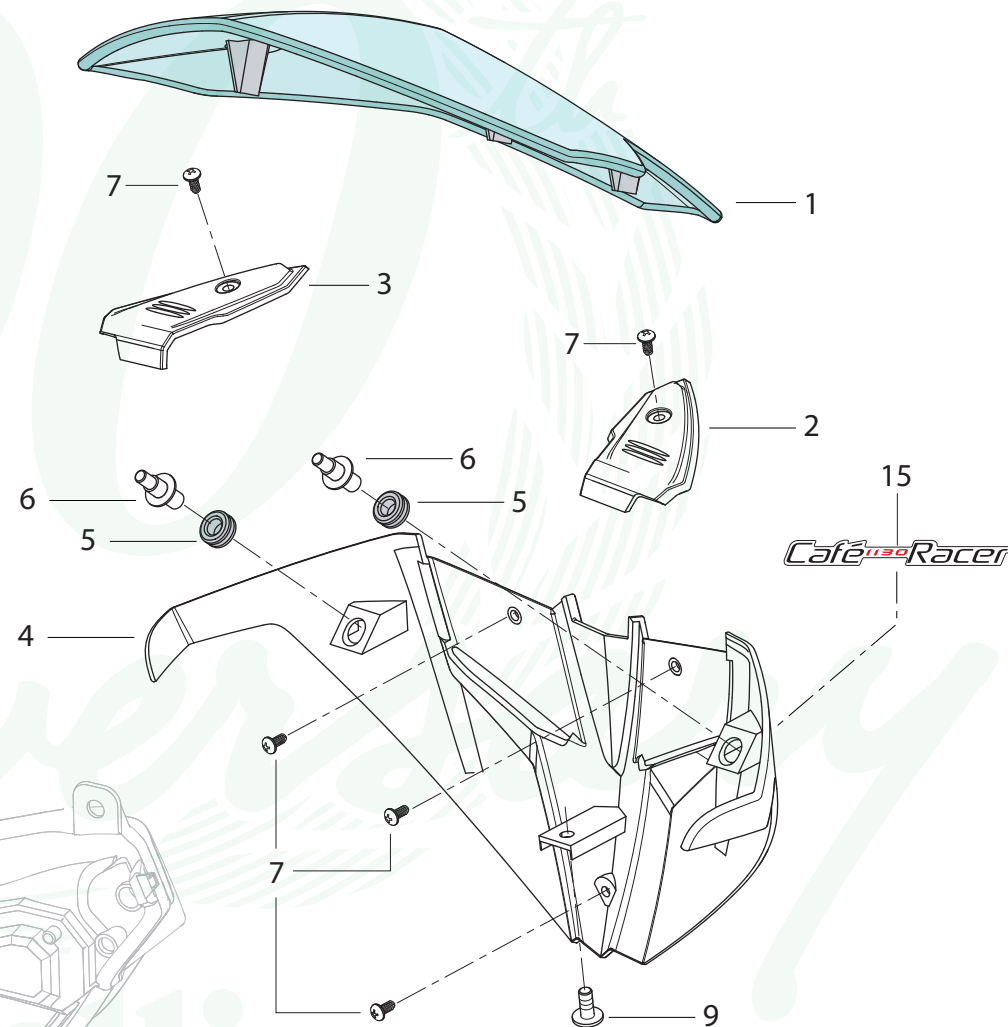
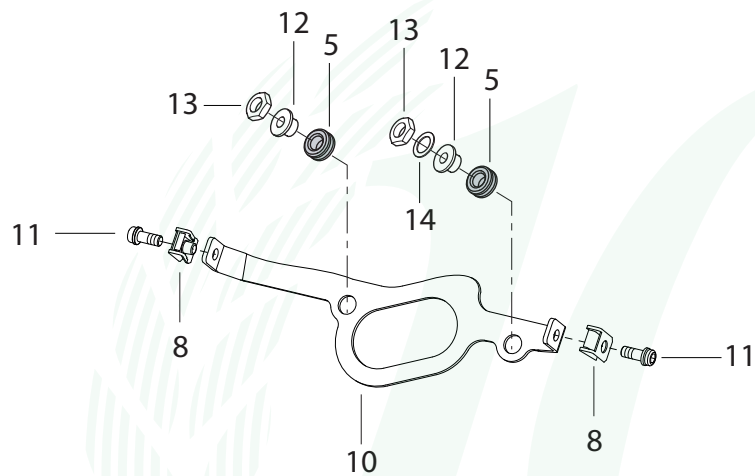

1911

Benelli

2011



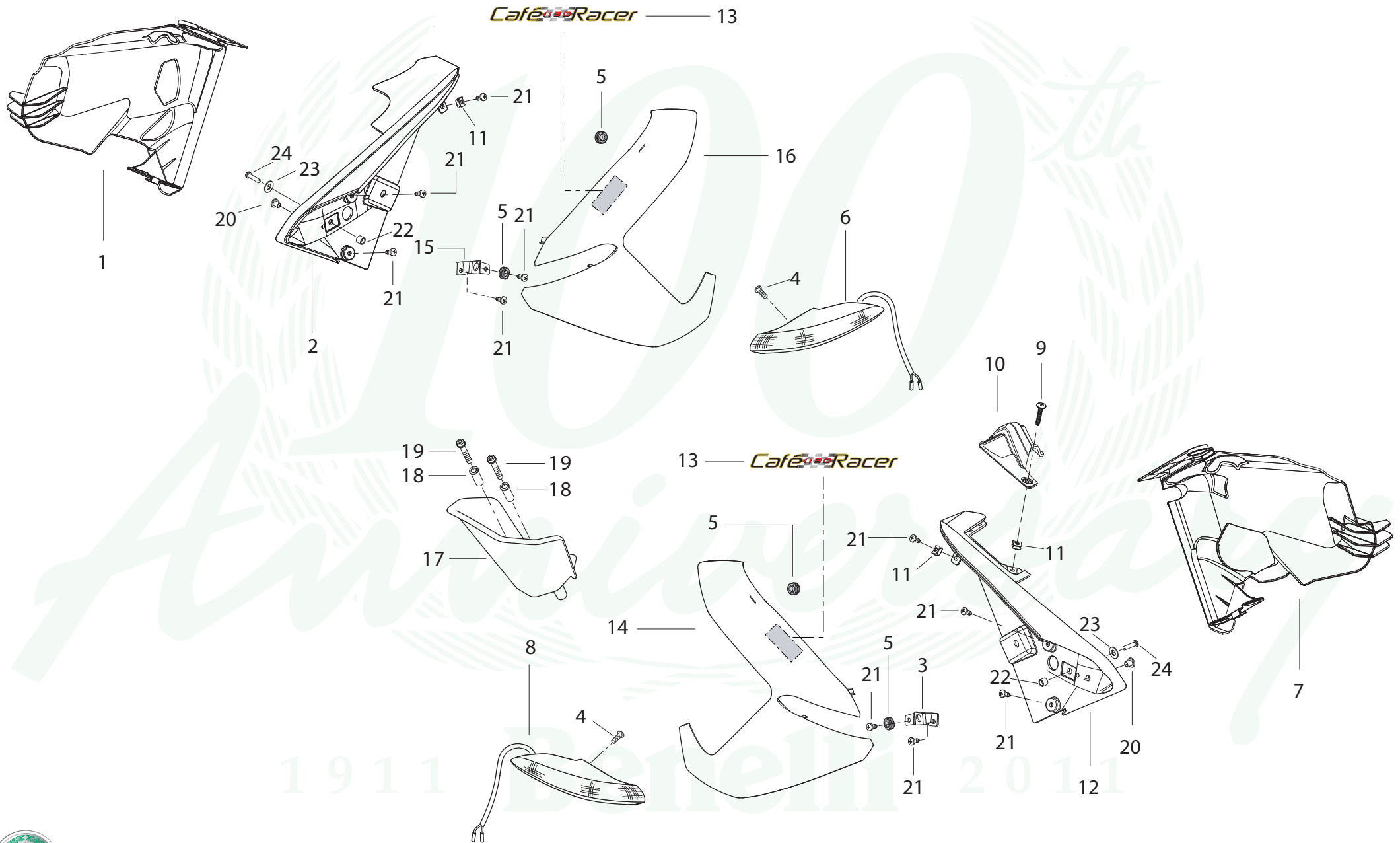

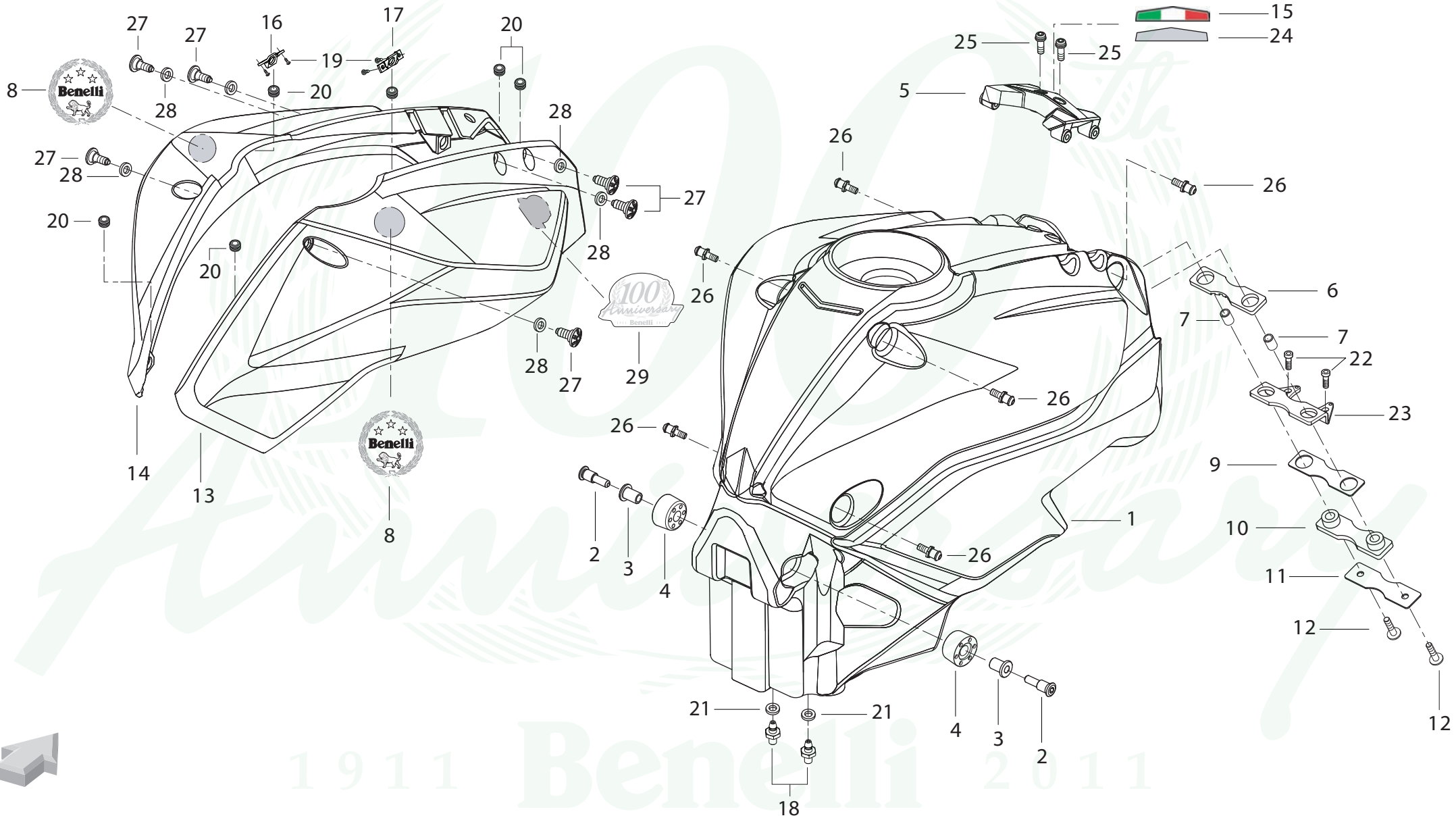

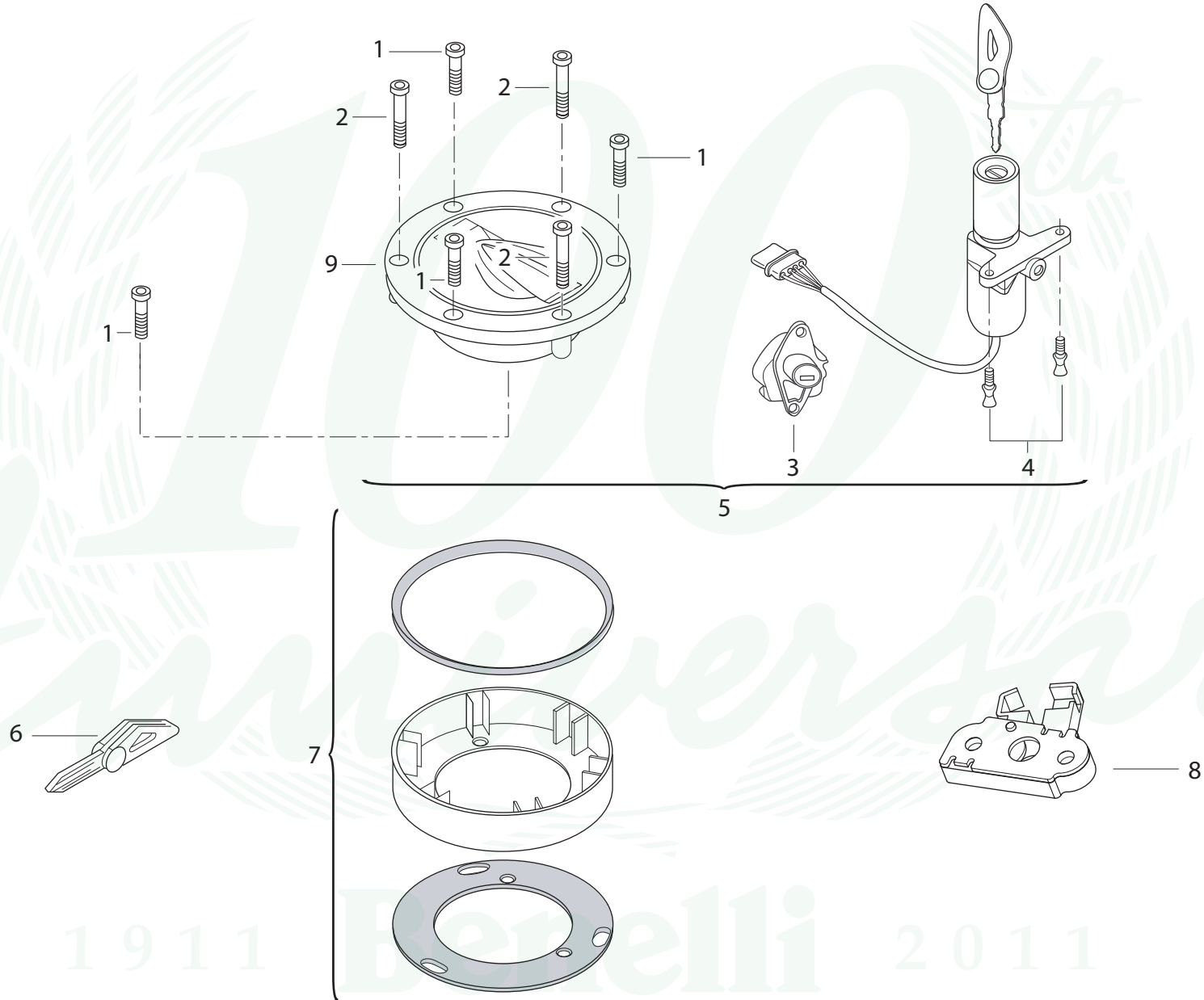



PROTEZIONE MOTORE



ENGINE PROTECTION



PROTECTION MOTEUR



SCHUTZ MOTOR



PROTECCIÓN MOTOR

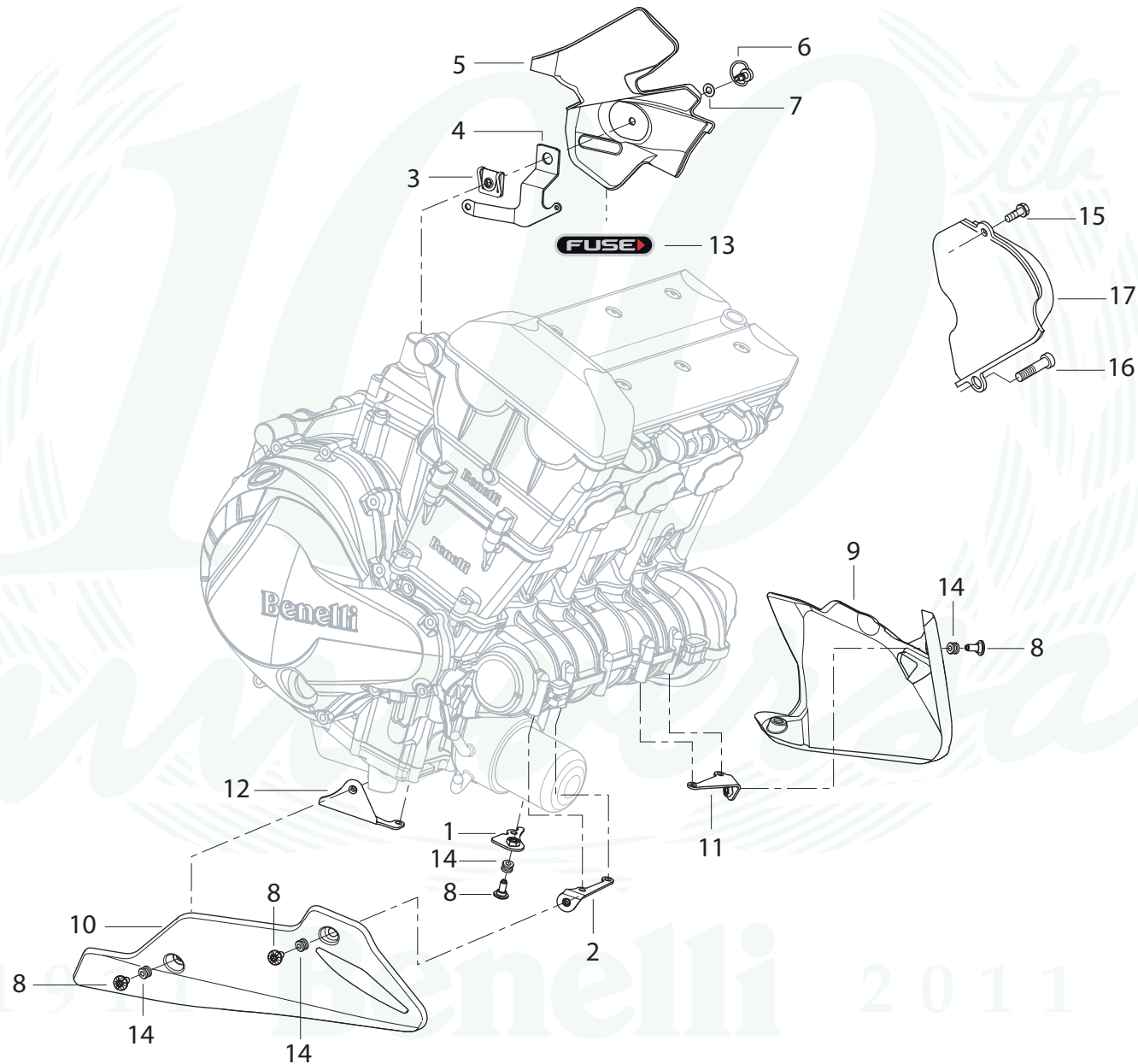

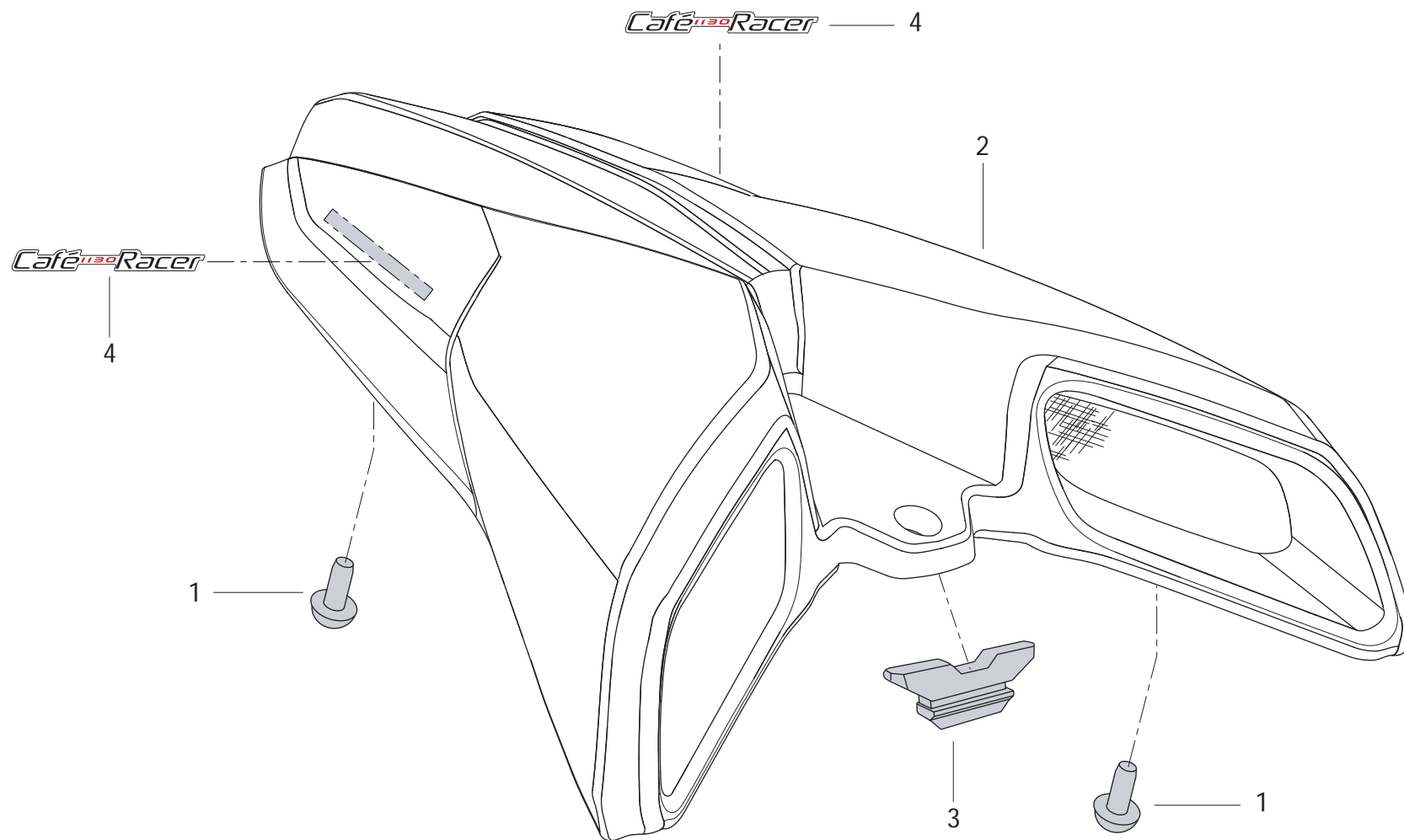



IL PRESENTE MANUALE È PROPRIETÀ DELLA
BENELLI Q.J. S.R.L.
OGNI PRODUZIONE, TOTALE O PARZIALE,
È VIETATA.

THIS MANUAL IS PROPERTY OF
BENELLI Q.J. S.R.L.
ANY TOTAL OR PARTIAL REPRODUCTION
IS FORBIDDEN.

CE MANUEL EST DE LA PROPRIÉTÉ DE
BENELLI Q.J. S.R.L.
TOURE REPRODUCTION TOTALE OU
PARTIELLE, ESTINTERDITE.

DIE VORLIEGENDE BEDIENUNGSANLEITUNG
STEHT IM EIGENTUM VON BENELLI Q.J. S.R.L.
JEDE VÖLLIGE ODERTEILWEISE KOPIE
IST VERBOTEN.

EL PRESENTE MANUAL ES PROPIEDAD
DE BENELLI Q.J. S.R.L.
SE PROHÍBE SU REPRODUCCIÓN
TOTAL O PARCIAL.



Benelli consiglia accessori originali
Benelli suggestions original accessories
Benelli conseiller accessoires original
Benelli raten Zubehör originell
Benelli aconsejar accesorios originales



1911 Benelli 2011
Ver.01 - Giu. 11
Benelli Q.J. s.r.l.
Strada della Fornace Vecchia n.3
61122 - Pesaro - Italy
www.benelli.com

